

Fiberglass Crank **Auto-Tilt** Market Umbrella

COMMERCIAL GRADE

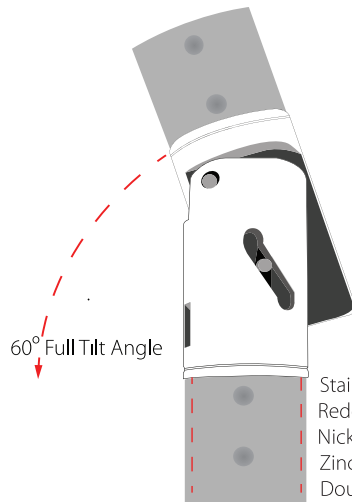

1/2" Diameter Fiberglass Ribs
 Heavy Gauge Resin & Stainless Steel Parts
 Heavy Gauge Crank System
 9oz. Marine Grade Fabric

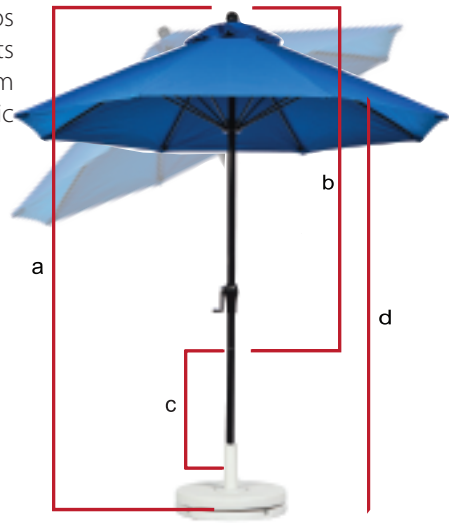

Stainless Steel Internal Structure
 Redesigned Zinc Alloy Internal Tilt Lever
 Nickel Plated Load Spring
 Zinc Alloy Pulley Wheel
 Double Locking Indentations

Dimensions

*all measurements are rounded

SHOWN: 845FMA-BK-PBA

KEY

✓: IN STOCK READY TO SHIP
 N/A: REQUIRES CUSTOM BUILD REQUEST
 ITEM NUMBERS HIGHLIGHTED IN RED

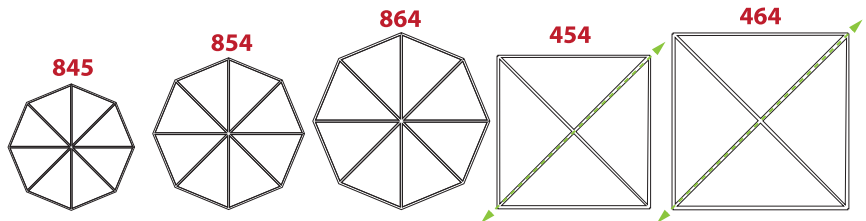

Fiberglass Market Umbrellas

| | | | | | |
|--|--------------|------------|-------------|-------------|--------------|
| a: Overall Height | 97" | 105" | 117" | 105" | 117" |
| b: Center Pole Length (no bottom pole) | 66" | 74" | 86" | 74" | 86" |
| c: Bottom Pole Length | 31" | 31" | 31" | 31" | 31" |
| d: Canopy to ground clearance | 82" | 87" | 99" | 87" | 99" |
| Pole Diameter | 1.5" | 1.5" | 1.5" | 1.5" | 1.5" |
| FM/FMC/FMA Pole Thickness | 2.3mm | 2.3mm | 2.3mm | 2.3mm | 2.3mm |
| Umbrella Weight | 21lbs | 24lbs | 27lbs | 21lbs | 24lbs |
| Diameter | 7.5' Octagon | 9' Octagon | 11' Octagon | 6.5' Square | 7.5' Square |
| | | | | 9' Diagonal | 11' Diagonal |

Frame Type Availability

| | | | | | |
|------------------------------------|---|---|---|---|---|
| Auto-Tilt Crank System: FMA | ✓ | ✓ | ✓ | ✓ | ✓ |
|------------------------------------|---|---|---|---|---|

Frame Color Availability

| | | | | | |
|-----------------------------------|---|---|---|---|---|
| Black Pole & Ribs: BK | ✓ | ✓ | ✓ | ✓ | ✓ |
| Bronze Pole & Ribs: BZ | ✓ | ✓ | ✓ | ✓ | ✓ |
| White Pole & Ribs: WH | ✓ | ✓ | ✓ | ✓ | ✓ |
| Wood Grain Pole & Ribs: WG | ✓ | ✓ | ✓ | ✓ | ✓ |
| Silver Pole & Ribs: SR | ✓ | ✓ | ✓ | ✓ | ✓ |

Packing Dimensions

| | | | | | |
|--|-----------|-----------|-----------|-----------|-----------|
| Dimensions of cardboard packaging | 69"x9"x9" | 79"x9"x9" | 79"x9"x9" | 79"x9"x9" | 79"x9"x9" |
| Weight of umbrella when packaged in carton (individually) | 21lbs. | 24lbs. | 25lbs. | 21lbs. | 22lbs. |
| Maxium per cardboard carton. | 3 | 3 | 3 | 3 | 3 |
| Weight of max. carton capacity | 66lbs | 75lbs | 78lbs | 66lbs | 71lbs |

9oz. Marine Grade Acrylic Fabric

Fabric Swatches



Finish Options

