

Linear Metal Ceiling Systems



HunterDouglasContract

CEILINGS

In Line with Style.

Forty years ago, Hunter Douglas pioneered suspended metal ceilings. We've been hard at work ever since, creating new solutions to meet the evolving requirements of architects, designers, and construction professionals across North America, Europe, Asia and beyond.

Luxalon® Metal Ceilings excel in design and performance, with linear, wide panel, and curved systems for a comprehensive range of interior and exterior applications. No matter your vision, we have the solution.

See product details and selected projects at www.hunterdouglascontract.com/ceilings

Project: BART Station
Location: San Francisco, CA
Architect: ED2 International
Product: Box 6, finish: Natural

CAPABILITIES	2
300A & 300C SYSTEMS	4
BOX SERIES	6
84R & 84G SYSTEMS	8
150F SYSTEM	10
3" & 6" V-GROOVE SYSTEMS	12
CURVED SYSTEM	13
PERFORATIONS & COLORS	14
SUSTAINABILITY	16

From Design to Delivery.

Hunter Douglas engineers its ceiling systems for design versatility, with industry-leading sizes, options, and colors, plus an exclusive universal carrier system that lets you mix and match widths and panel depths. Then we control every step of the manufacturing process to ensure quality, from smelting the metal into a smooth, stable coil, to forming and finishing the panels. No matter the style, our linear systems deliver the look you want.

Project: Shanghai Pudong International Airport Terminal 2
Location: Shanghai, China
Architect: East China Architectural Design & Research Institute
Product: Box 8



Project: National Ballet School of Canada
Location: Toronto, Canada
Architect: KPMB
Product: Box 6, Deep Box 2 and Deep Box 6

Hunter Douglas has decades of experience in designing and manufacturing ceilings, and it shows in every detail of our products.

- Complete vertical integration, from raw metal to finished panel
- Standard “run to length” manufacturing
- Easy installation: panels snap in without fasteners
- Solutions for straight, curved, and specialty configurations
- Variety of edge details – round, square, beveled
- Range of panel sizes – widths from 2" to nearly 12"; lengths from 3' to 19' 8"
- Variety of finish options, including metallic, wood and wood-look, and complete range of colors
- Panels and finishes formulated to ensure interior air quality
- Aluminum panels contain 70% to 95% recycled content



Project: Agora Theater
Location: Lelystad, Netherlands
Architect: UNStudio, Ben van Berkel
Product: Deep Box 2

Impressive Size. Impressive Panel.



For designs that need to make a big impression, the long, uninterrupted panel lengths of our 300A and 300C systems are the choice. With lengths up to 19' 8", 300A and 300C panels require fewer seams and joints. Our concealed suspension system complements this clean appearance to create a sleek, monolithic look.

Project: Sears Centre
 Location: Hoffman Estates, IL
 Architect: Ryan Companies
 Product: 300C, color: Natural

300A PANEL – REVEAL

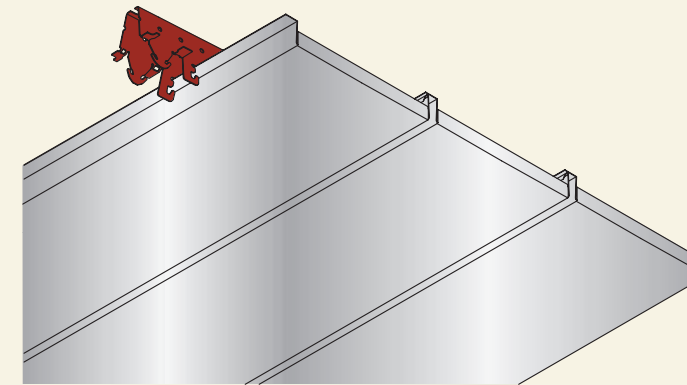

300C PANEL – BEVEL

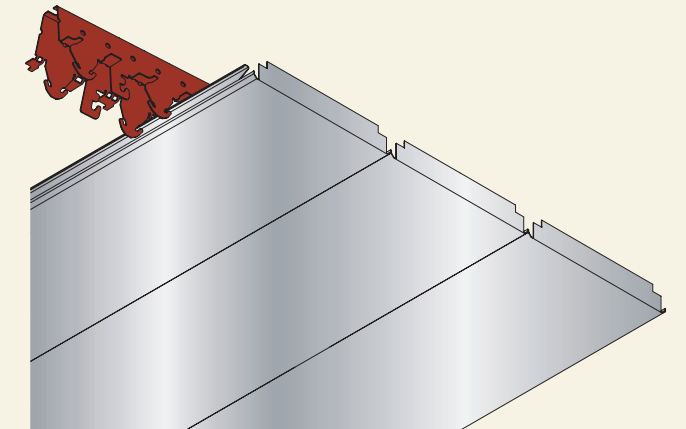

PANEL MODULE-REVEAL

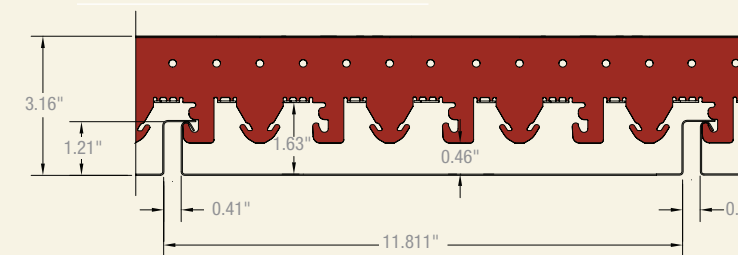

PANEL MODULE-BEVEL

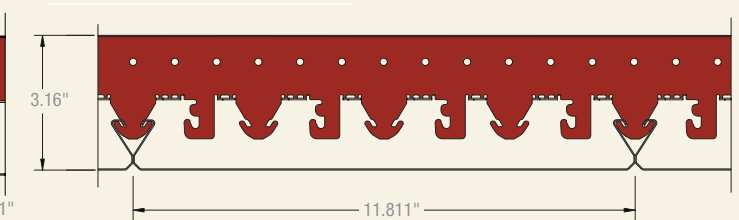

300A AND 300C SYSTEMS FEATURE

- Standard sizes 3' to 19' 8"
 - Simple, economical installation
 - Panels span greater distances than other systems, reducing number of carriers
 - Concealed suspension system to emphasize clean, monolithic appearance
 - Easy access/point accessibility to plenum – no special tools required
 - Compatible with industry-standard fixtures and air diffusers
 - Perimeter trim options available
 - Panels contain from 70% to 95% recycled content
 - Interior and exterior applications available
- See pp. 14-15 for colors, finishes, and perforation/acoustical options, or visit www.hunterdouglascontract.com/ceilings

Think Inside the Box.

The defined, square edges of Luxalon® Box and Deep Box systems create a crisp, modular ceiling for interior and exterior applications. All panels fit our exclusive universal carrier, allowing mix-and-match patterns to establish texture and pattern.

Project: Fatbursjon
 Location: Stockholm, Sweden
 Architect: Gert Wingardh
 Product: Multi-Box Panel: Box 2, 4, 6, 8 and Deep Box 2

MULTI-BOX SYSTEM OPTION

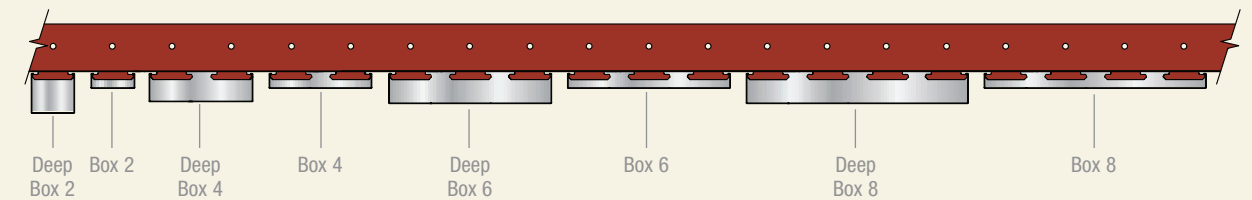

DEEP BOX 2

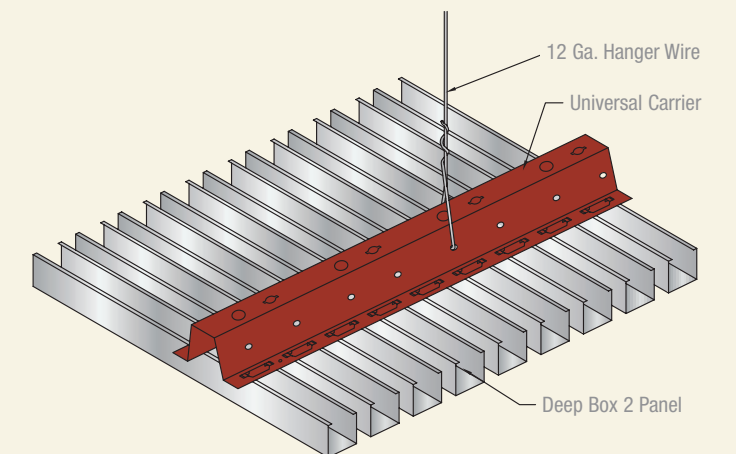

DEEP BOX 4

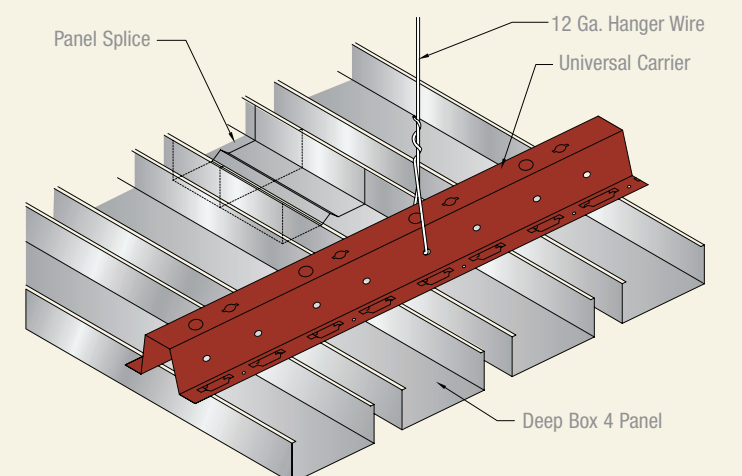

LUXALON® BOX AND DEEP BOX SYSTEMS FEATURE

- Panel widths: 2", 4", 6", and 8"
- Panel depths (nominal)
 - 5/8" (Box)
 - 1-1/2" (Deep Box 2)
- Easy installation – no fasteners required
- Built-in provisions for acoustics, HVAC, and lighting
- Box systems have crisp edges for precision reveals. Deep Box profiles allow stronger reveals
- Easy access to plenum
- Perimeter trim options available
- Panels contain from 70% to 95% recycled content
- Interior and exterior applications available

See pp. 14-15 for colors, finishes, and perforation/acoustical options, or visit www.hunterdouglascontract.com/ceilings

Just Around the Bend.

The 84R and 84G systems are known for their attractive, fluid lines. Usually applied in straight linear configurations, our panels can also be curved (as shown above). Appropriate for interior and exterior locations, both systems can make a dramatic statement, soften conventional corners, or create sophisticated transitions.

Project: ZhouShan Grand Theatre
 Location: ZhouShan, China
 Architect: Architecture Design and Research Institute of Zhe-Jiang University
 Product: 84R Curved

84R PANEL

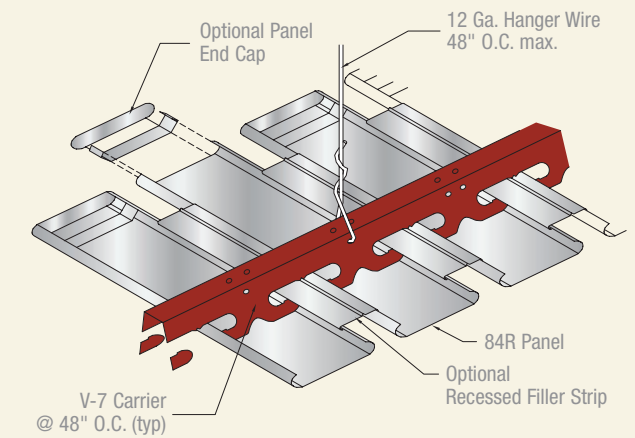
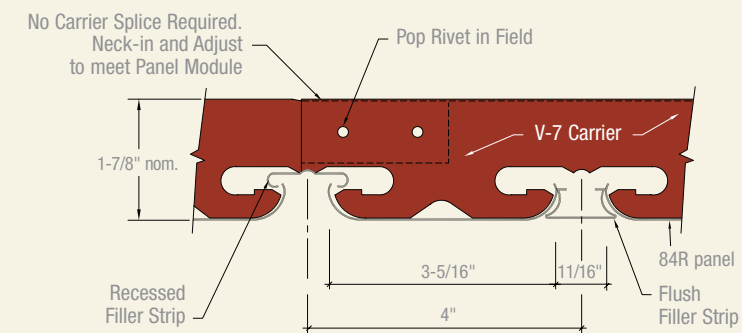

84G PANEL

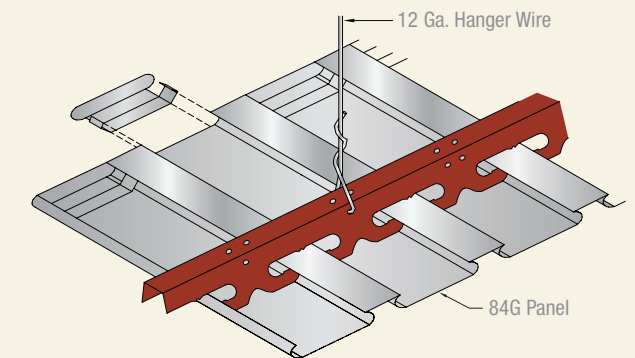
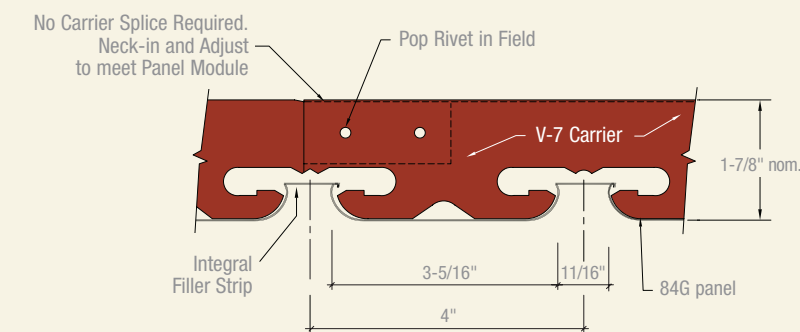

84R AND 84G SYSTEMS FEATURE

- Precise directional control, with support for virtually any design configuration
- 84R can be made into a closed system with either a recessed filler strip or flush filler strip in matching or contrasting colors
- 84G has an integral closure feature which is available in standard or specified colors
- Both systems accommodate lighting, air, and sprinkler fixtures and are easy to install and maintain
- Profiles can be curved (see page 13). 84R panels accommodate tight radii of 12 3/4" and 28" (or any radius of 48" or more)
- Perimeter trim options available
- Panels contain from 70% to 95% recycled content
- Interior and exterior applications available

See pp. 14-15 for colors, finishes, and perforation/acoustical options, or visit www.hunterdouglascontract.com/ceilings

Take it Outside.

Specifically designed to withstand harsh environments, the 150F Exterior ceiling system has been widely used for applications ranging from soffits and exterior metal ceilings to painted façades. This economical system requires no fasteners and provides a flush look with an even, solid surface. Appropriate for vertical and horizontal installations, with an engineered carrier system that provides excellent resistance to wind pressure. High-performance finish resists scuffing and fading.

Project: Staples Center
 Location: Los Angeles, CA
 Architect: NBBJ – LA
 Product: 150F, color: Natural

150F EXTERIOR SYSTEM

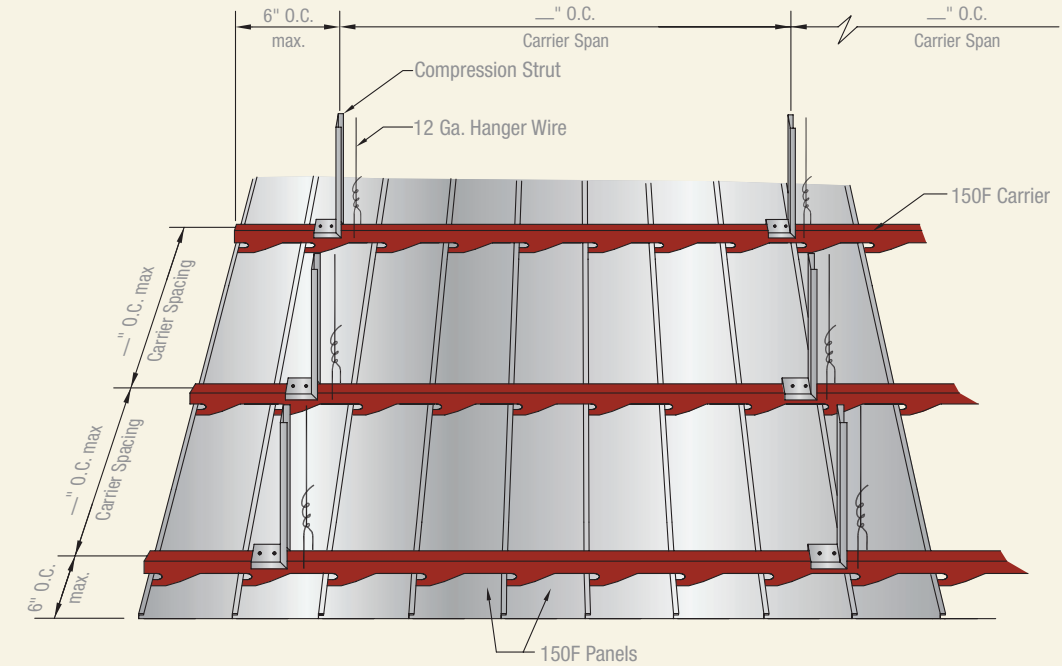

WIND LOAD CHART		
Design Wind Pressure (PSF)	Carrier Spacing* (Panel Span)	Carrier Span (Rigid Support Spacing)
20	49"	20"
25	40"	20"
30	34"	20"
35	29"	20"
40	26"	20"

* Note: Carrier Spacing based on using 3 or more carriers
 For complete technical information, contact Hunter Douglas Contract at 800-366-4327 or visit www.hunterdouglascontract.com

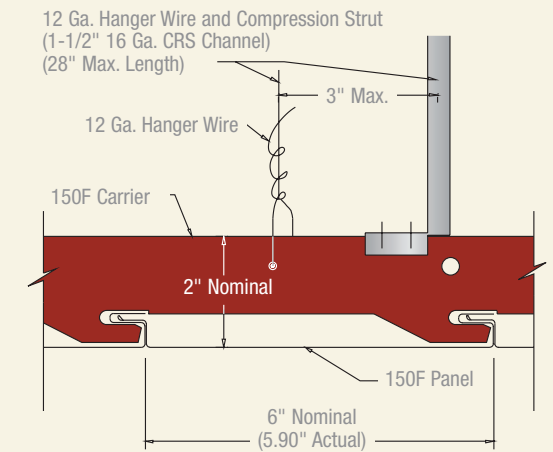

150F EXTERIOR SYSTEM FEATURES

- Carriers and panels designed to withstand positive/negative wind loads
- Perforations available for ventilation and/or acoustics
- Easy installation – no fasteners required
- Perimeter trim options available
- Available doors allow for plenum access
- Available in standard polyester or high-performance Luxacote finishes
- Luxacote® high-performance finish resists harsh environmental conditions including UV
- Stable to UV to resist color fading
- Panels contain from 70% to 95% recycled content

See pp. 14-15 for colors, finishes, and perforation/acoustical options, or visit www.hunterdouglascontract.com/ceilings

Project: InBev
 Location: Leuven, Belgium
 Architect: Popocini & Lootens
 Product: 6" V-Groove



V-Groove panels create a subtle linear effect, with fine beveled edges in 3" and 6" widths.

V-GROOVE SYSTEM FEATURES

- Tongue-and-groove appearance
- Available perforations with non-woven textile backing for acoustical applications
- Easy access to plenum
- Perimeter trim options available
- Panels contain from 70% to 95% recycled content

See pp. 14-15 for colors, finishes, and perforation/acoustical options, or visit www.hunterdouglascontract.com/ceilings

6" V-GROOVE

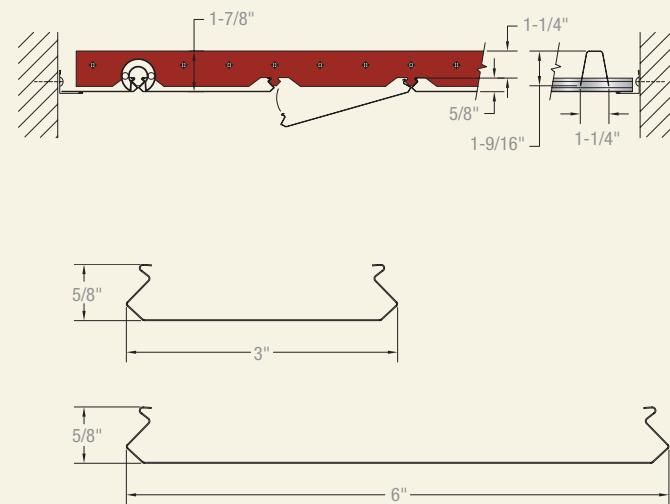
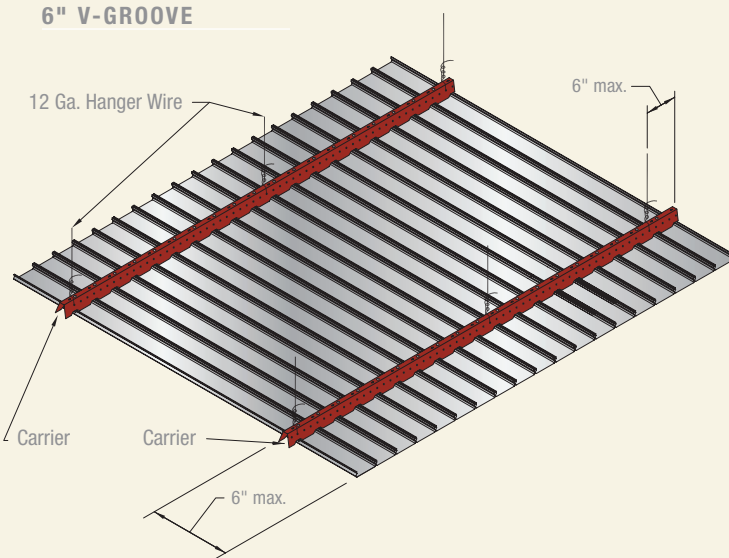

Project: Ian Thorpe – Aquatic Center
 Location: Sydney, Australia
 Architect: Harry Seidler and Associates
 Product: 84R Curved, color: Polar White



Our curved ceilings add a twist to the traditional in concave, convex, or undulating forms. Our flexible carrier system enables creation of curved ceilings with straight panels. By using standard panels and production processes, Hunter Douglas' curved carriers make curved metal ceilings truly cost effective. The system is compatible with 84R, 84G, and all Box Series panels (2", 4", 6" and 8").

Curved 84R panels are factory formed into concave or convex shapes along the length of the panels. A range of radii are available, including 12-3/4", 28", and any radius of 48" or more.

STRAIGHT PANEL WITH CURVED CARRIER (84R & 84G, ALL BOX SERIES PANELS)

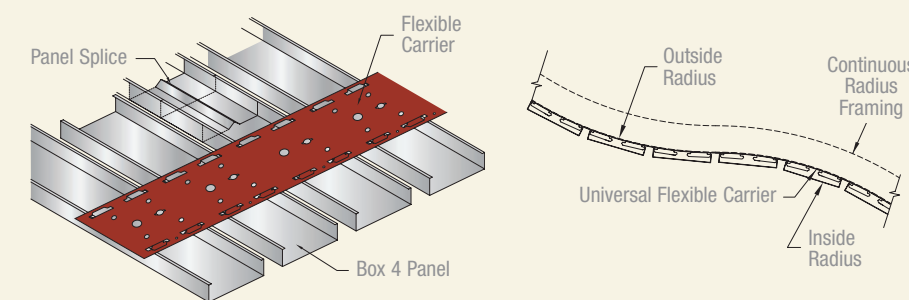

CURVED FEATURES

- Same easy panel-on-carrier suspension system as our standard ceilings, allowing easy transition from curved to straight using the same panel
- Systems easily accommodate lighting, air, and sprinkler fixtures
- Interior and exterior applications available
- Perimeter trim options available
- Panels contain from 70% to 95% recycled content

See pp. 14-15 for colors, finishes, and perforation/acoustical options, or visit www.hunterdouglascontract.com/ceilings

CURVED PANEL WITH STRAIGHT CARRIER (84R ONLY)

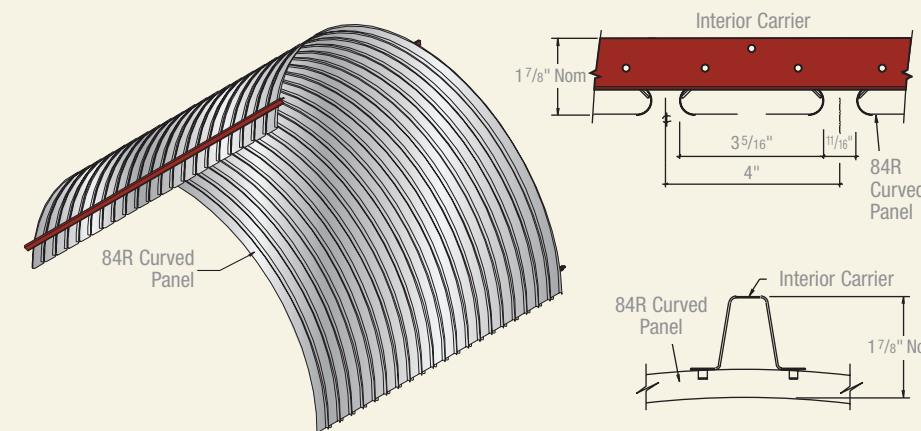

PERFORATIONS

Perforated panels improve acoustical performance as well as creating aesthetic effects. Perforation patterns may be product specific. Visit www.hunterdouglascontract.com/ceilings for further details.

#124

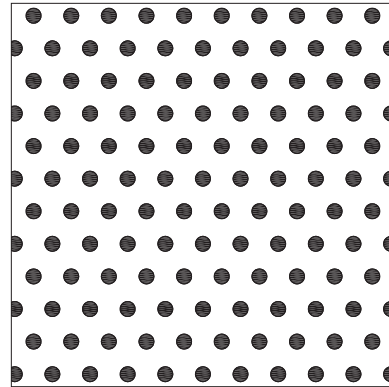

Perforation diam: .078 in.
Open area: 15%

#140

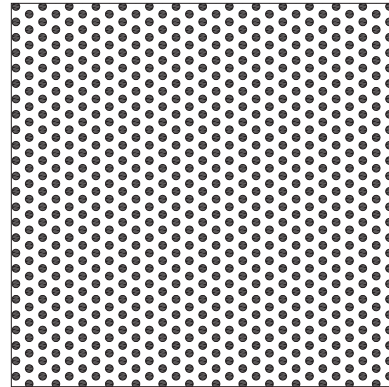

Perforation diam: .040 in.
Open area: 23%

#160

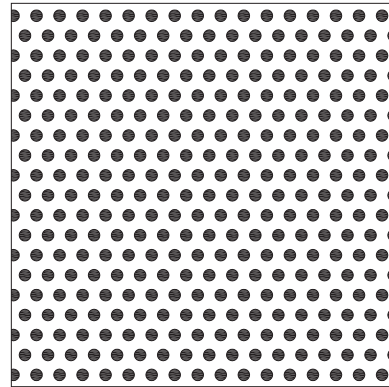

Perforation diam: .060 in.
Open area: 23%

SOUND ABSORPTION (NRC) SUMMARY*

Product	Perforation Pattern	% Open Area	Acoustical Infill	NRC
300A, 300C, Box Series 84R, 84G, 150F 3" & 6" V-Groove	#124	15%	1" – 1.5 pcf Polywrapped Fiberglass Non-Woven Acoustic	0.85 0.75
Box 4, 84R, 3" V-Groove	#140	23%	1" – 1.5" pcf Mineral Wood Pad 1.5" – 1.5 pcf Polywrapped Fiberglass	0.75 1.00
Box 4, 84R, 3" V-Groove	#140	23%	1" – 1.5 pcf Mineral Wood Pad and Non-Woven Acoustic	0.85
300A & 300C	#160	23%	1" – 1 pcf Polywrapped Fiberglass and Non-Woven Acoustic Non-Woven Acoustic	0.95 0.70

* Acoustical tests performed in accordance with ASTM C423 and ASTM E795, in a type E400 mounting. Test reports available upon request.



Project: JFK, Terminal 1
Location: New York, NY
Architect: William Nicolas Bodouva & Associates
Product: 300C, color: Natural, perf pattern: #160
with black non-woven acoustic backing

FINISH OPTIONS

In addition to our standard finishes, Hunter Douglas offers a wide range of additional finish options, including custom color matching, simulated woods, and custom designs. Finish options may be product specific. Minimum quantities, pricing variations, and lead times may apply.



Cotton White #0280

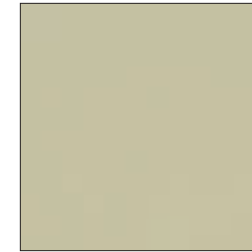

Fawn #4482



Natural #7163



Brushed Natural #7007

Laminated Wood Veneer Finishes

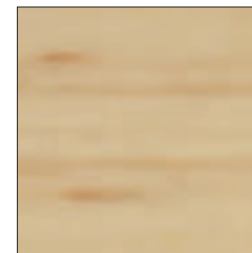

Maple Wood Veneer #9002

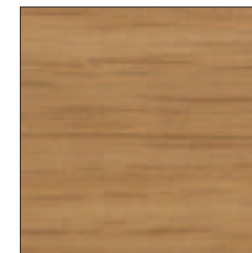

White Oak Veneer #9003



Red Oak Veneer #9004

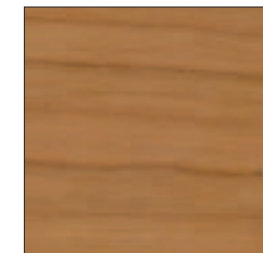

Cherry Veneer #9013



Bamboo Veneer #9014

Simulated Wood Finishes



Beech #6812



American Natural #8000



Russian Maple #8003

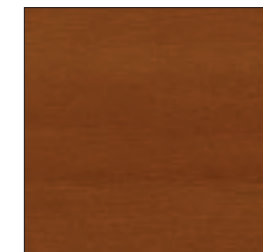

Cherry #6813

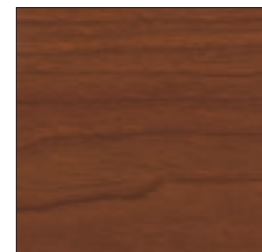

Hayward Cherry #8005

Luxacote Exterior Finishes

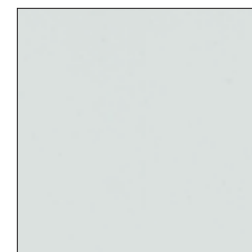

Lighthouse White #0401



Fawn #4465



Natural #7080

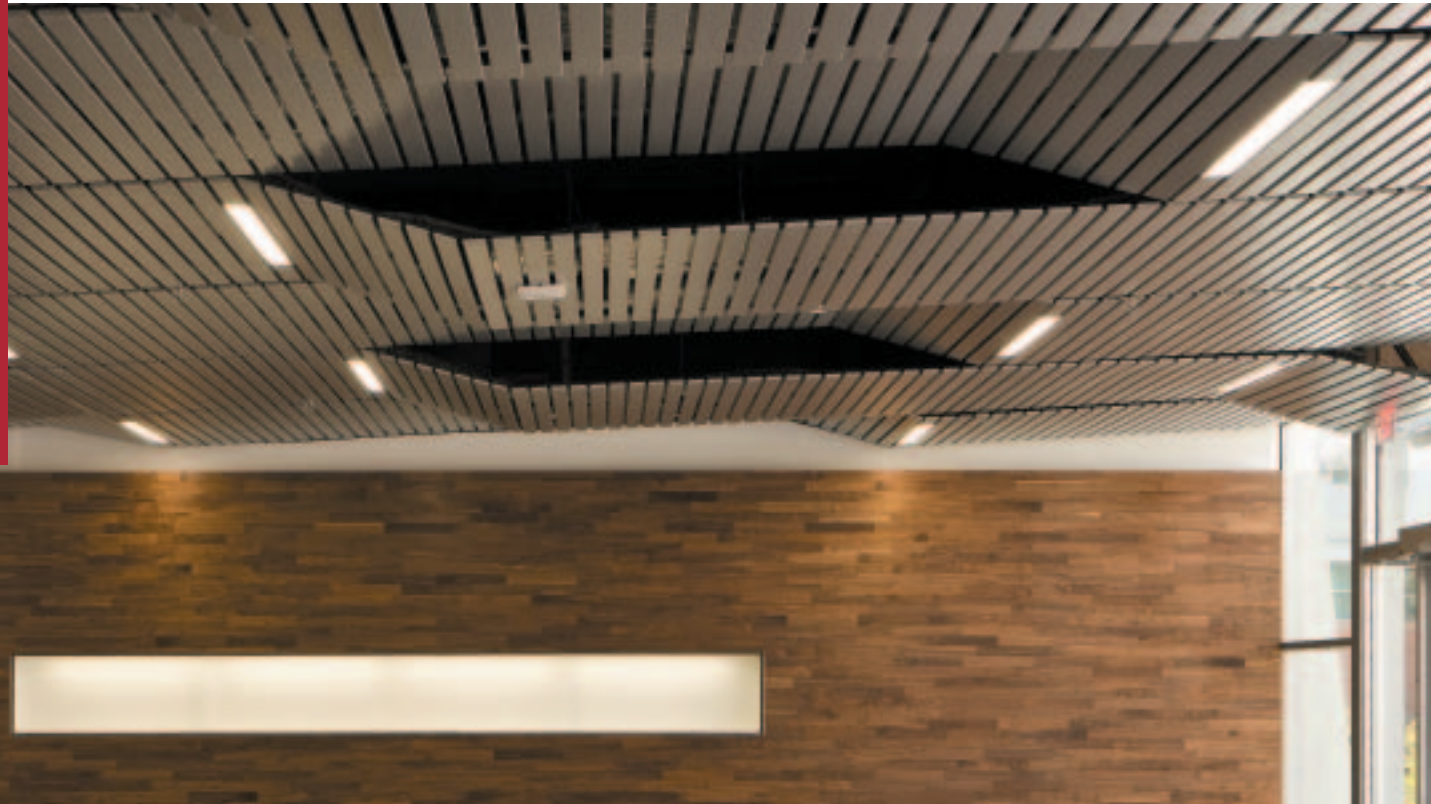

Hunter Douglas has long designed and manufactured its ceiling systems to follow the principles of sustainability and indoor environmental quality. We have the experience, the knowledge and the products. Visit www.hunterdouglascontract.com/ceilings and click on the "Green Product Bulletin" for further details.

Key environmental programs and features:

- Our U.S. manufacturing location, which produces all our metal ceiling systems for the North American market, qualifies as a zero landfill facility
- Hunter Douglas Contract is a longtime member of the U.S. Green Building Council
- Hunter Douglas has an ongoing commitment to research that improves the sustainability of our sourcing and manufacturing process.

LEED EXPERTISE

Our project managers and engineers have worked on many LEED® rated and/or sustainably designed projects, from manufacturing facilities to high-rise office towers. Contact us for more information on products and documentation for projects that include environmental design considerations.



Our project managers and engineers can assist architects/designers in a number of key areas to accumulate potential LEED® credits toward project certifications.

- MR Credit 2.1 and 2.2
 - Our aluminum ceiling panels are factory-cut to size, significantly reducing field cutting and scrap.
- MR Credit 4.1 and 4.2
 - Our aluminum ceilings contain from 70% to 95% recycled content. Approximately 50% is post-consumer.
- EQ Credit 3.1 and 3.2
 - Our metal ceiling panels have no reportable VOC's.
- EA Credit 1
 - Our metal ceiling panels may have a light reflectance of (LR) 1 which may contribute to energy savings.

Photo at left

Project: James E. Rogers College of Law, University of Arizona
 Location: Tucson, AZ
 Architect: Gould Evans
 Product: Box 4, color: Natural

Cover

Project: Indianapolis Airport
 Location: Indianapolis, IN
 Architect: AeroDesign Group & HOK
 Product: 300C, color: Polar White



Project: Bush Intercontinental Airport
 Location: Houston, TX
 Architect: Gensler, Houston
 Product: Hook-On



Project: Adam & Eve Hotel
 Location: Belek-Antalya, Turkey
 Architect: Eren Talu
 Product: Open Cell

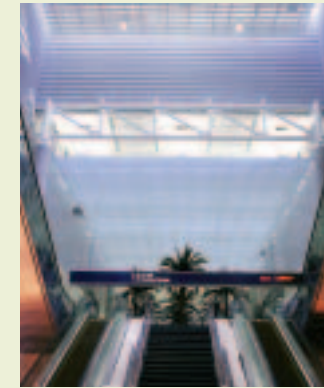

Project: Ft. Lauderdale Airport
 Location: Ft. Lauderdale, FL
 Architect: HOK
 Product: Screen/Baffle

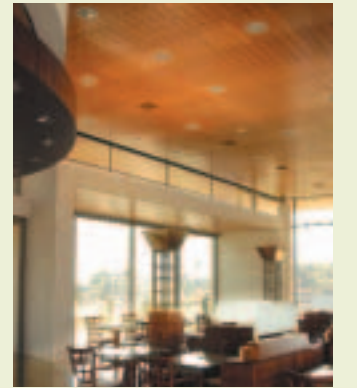

Project: Hotel Plaza El Bosque
 Location: Santiago, Chile
 Architect: Fernandez – Wood Arquitectos
 Product: Natura

As architects and designers expand the boundaries of design, Hunter Douglas continues to work alongside them. Our ceiling systems are found in some of the world's most recognizable projects.

Learn More

- Call 800-366-4327 to speak with a ceilings specialist
- www.hunterdouglascontract.com/ceilings
- Sign up online to receive a monthly email bulletin

HunterDouglasContract

WINDOW COVERINGS | CEILINGS | SOLAR CONTROL | FAÇADES



Hunter Douglas Contract
5015 Oakbrook Parkway, Suite 100
Norcross, GA 30093
phone: 800.366.4327
fax: 770.806.0214
www.hunterdouglascontract.com/ceilings

©2009 Hunter Douglas Inc. ® is a trademark of Hunter Douglas Inc.

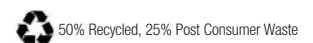

50% Recycled, 25% Post Consumer Waste