

# TUBRISE

E X T E R I O R   S C R E E N

## HunterDouglasContract

### CEILINGS

1 Hunter Douglas Circle  
Thornton, CO 80241  
800-727-8953  
fax: 720-872-7850

5015 Oakbrook Parkway, Suite 100  
Norcross, GA 30093  
800-366-4327 / 770-806-9557  
fax: 770-806-0217

[www.hunterdouglascontract.com](http://www.hunterdouglascontract.com)

## TUBRISE

PRODUCT CATEGORY: SOLAR CONTROL - EXTERIOR SCREEN  
DRAWING FILE: TUBRISE\_EXTERIOR SCREEN\_TITLE PAGE

**LUXALON**<sup>®</sup>  
METAL CEILINGS

**WoodWright**<sup>™</sup>  
WOOD CEILINGS

**Techstyle**<sup>®</sup>  
ACOUSTIC SOLUTIONS

*All rights reserved. This drawing is the property of Hunter Douglas and may be used only in conjunction with construction projects utilizing Hunter Douglas products. This detail may not apply to all conditions or construction situations. For non-typical conditions, consult Hunter Douglas.*

drawn: CKS  
date: 04-11  
section: TUBE  
page: TITLE

DETAIL	PAGE
Product Description	01
Components	02
Horizontal Installation with Folded Bracket	03
Horizontal Installation Section with Folded Bracket	04
Horizontal Installation Corners with Folded Bracket	05
Horizontal Installation with Square Bracket	06
Horizontal Installation Section with Square Bracket	07
Horizontal Installation Corner with Square Bracket	08
Horizontal Installation with C-Channel	09
Vertical Installation with Square Bracket	10
Vertical Installation Section with Square Bracket	11
Vertical Installation Corners with Square Bracket	12
End Cap Components	13
Horizontal Installation with End Caps and Square Bracket	14
Perforation Pattern 103	15
Perforation Pattern 118	16

## HunterDouglasContract

### CEILING

1 Hunter Douglas Circle  
Thornton, CO 80241  
800-727-8953  
fax: 720-872-7850

5015 Oakbrook Parkway, Suite 100  
Norcross, GA 30093  
800-366-4327 / 770-806-9557  
fax: 770-806-0217

[www.hunterdouglascontract.com](http://www.hunterdouglascontract.com)

### TABLE OF CONTENTS

PRODUCT CATEGORY: SOLAR CONTROL - EXTERIOR SCREEN  
DRAWING FILE: TUBRISE\_EXTERIOR SCREEN  
\_TABLE OF CONTENTS

**LUXALON**<sup>®</sup>  
METAL CEILING

**WoodWright**<sup>™</sup>  
WOOD CEILING

**Techstyle**<sup>®</sup>  
ACOUSTIC SOLUTIONS

All rights reserved. This drawing is the property of Hunter Douglas and may be used only in conjunction with construction projects utilizing Hunter Douglas products. This detail may not apply to all conditions or construction situations. For non-typical conditions, consult Hunter Douglas.

drawn: CKS  
date: 04-11  
section: TUBE  
page: TOC

PRODUCT DESCRIPTION - Galvalume:

Max Length: 19'-8.22" [6 meters]  
Yield Ratio: 6.0 Lft/sq.ft. [19.6 Lm/sqM]  
Unperforated:  
    Thickness: 0.016" [0.4 mm]  
Perforations 103 and 118:  
    Thickness: 0.050" [0.5 mm]  
    Weight: 2.167 lb/sq ft [10.58 Kg/sqM]

PRODUCT DESCRIPTION - Aluminum:

Max Length: 19'-8.22" [6 meters]  
Yield Ratio: 6.0 Lft/sq.ft. [19.6 Lm/sqM]  
Unperforated and Perforations 103 and 118:  
    Thickness: 0.024" [0.6 mm]  
Unperforated and Perforation 103:  
    Thickness: 0.031" [0.8 mm]  
    Weight: 1.284 lb/sq ft [6.27 Kg/sqM]

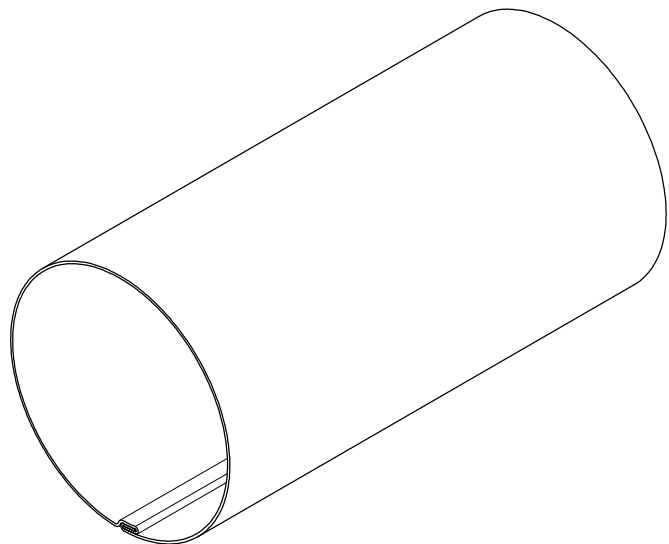
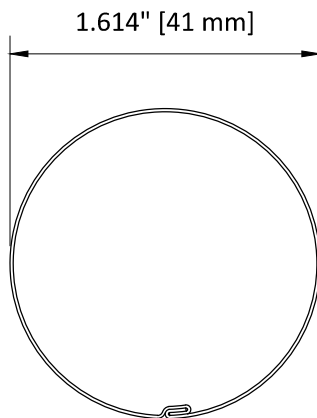

# HunterDouglasContract

## CEILINGS

1 Hunter Douglas Circle  
Thornton, CO 80241  
800-727-8953  
fax: 720-872-7850

5015 Oakbrook Parkway, Suite 100  
Norcross, GA 30093  
800-366-4327 / 770-806-9557  
fax: 770-806-0217

[www.hunterdouglascontract.com](http://www.hunterdouglascontract.com)

## TUBRISE PRODUCT DESCRIPTION

PRODUCT CATEGORY: SOLAR CONTROL - EXTERIOR SCREEN  
DRAWING FILE: TUBRISE\_ES\_PRODUCT DESCRIPTION  
SCALE: 1:1

**LUXALON**<sup>®</sup>  
METAL CEILINGS

**WoodWright**<sup>™</sup>  
WOOD CEILINGS

**Techstyle**<sup>®</sup>  
ACOUSTIC SOLUTIONS

All rights reserved. This drawing is the property of Hunter Douglas and may be used only in conjunction with construction projects utilizing Hunter Douglas products. This detail may not apply to all conditions or construction situations. For non-typical conditions, consult Hunter Douglas.

drawn: CKS  
date: 04-11  
section: TUBE  
page: 01

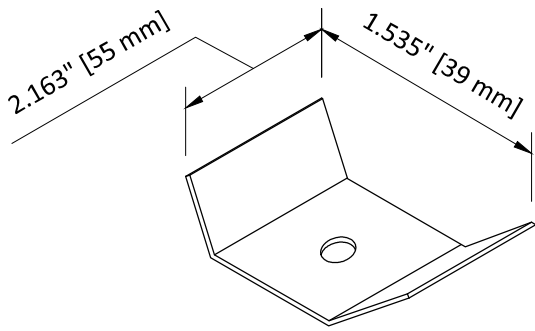

MATERIAL: Galvalume  
THICKNESS: 0.024" [0.6 mm]

TUBRISE CLIP

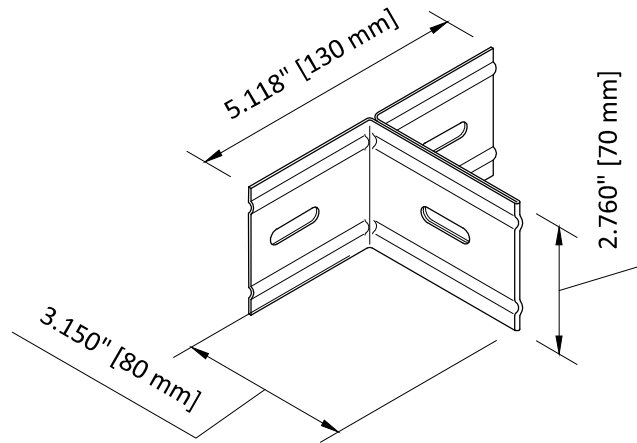

TUBRISE FOLDED BRACKET

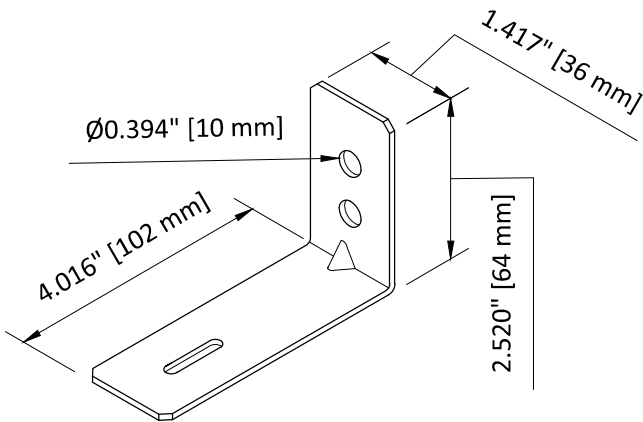

TUBRISE SQUARE BRACKET

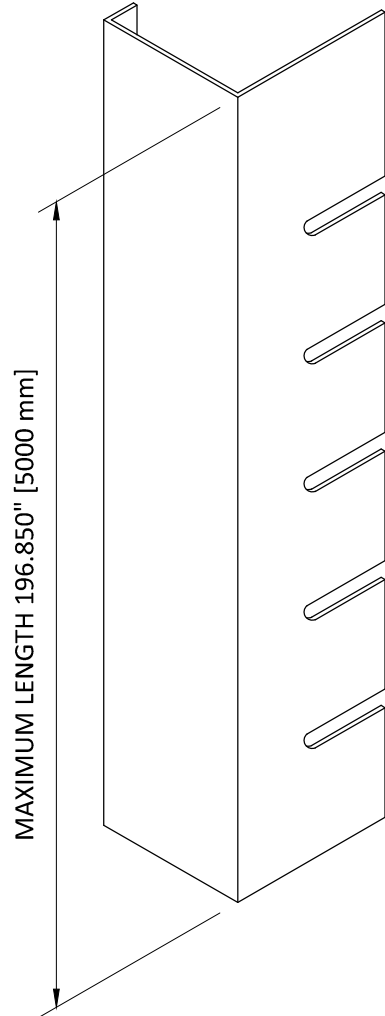

THICKNESS: 0.047" [1.2 mm]

TUBRISE SLOTTED MULLION

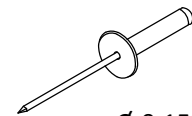

Ø 0.157" x 0.630"  
[Ø 4 mm x 16 mm]

TUBRISE POP RIVET

# HunterDouglasContract

## CEILING

1 Hunter Douglas Circle  
Thornton, CO 80241  
800-727-8953  
fax: 720-872-7850

5015 Oakbrook Parkway, Suite 100  
Norcross, GA 30093  
800-366-4327 / 770-806-9557  
fax: 770-806-0217

[www.hunterdouglascontract.com](http://www.hunterdouglascontract.com)

## TUBRISE COMPONENTS

PRODUCT CATEGORY: SOLAR CONTROL - EXTERIOR SCREEN  
DRAWING FILE: TUBRISE\_ES\_COMPONENTS  
SCALE: NOT TO SCALE

**LUXALON**<sup>®</sup>  
METAL CEILING

**WoodWright**<sup>™</sup>  
WOOD CEILING

**Techstyle**<sup>®</sup>  
ACOUSTIC SOLUTIONS

All rights reserved. This drawing is the property of Hunter Douglas and may be used only in conjunction with construction projects utilizing Hunter Douglas products. This detail may not apply to all conditions or construction situations. For non-typical conditions, consult Hunter Douglas.

drawn: CKS  
date: 04-11  
section: TUBE  
page: 02

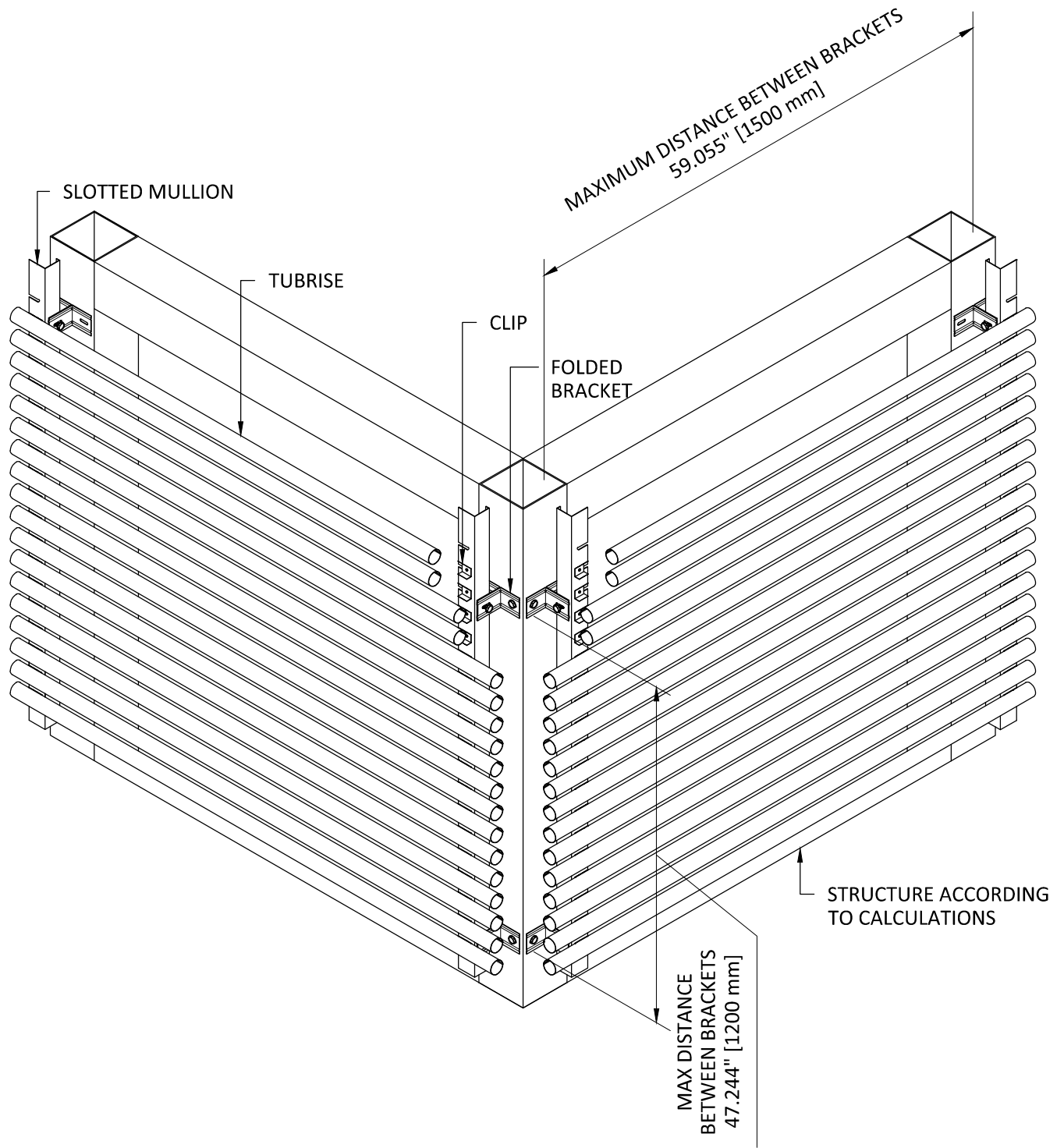

# HunterDouglasContract

## CEILING

1 Hunter Douglas Circle  
 Thornton, CO 80241  
 800-727-8953  
 fax: 720-872-7850

5015 Oakbrook Parkway, Suite 100  
 Norcross, GA 30093  
 800-366-4327 / 770-806-9557  
 fax: 770-806-0217

[www.hunterdouglascontract.com](http://www.hunterdouglascontract.com)

## TUBRISE - HORIZONTAL INSTALLATION WITH FOLDED BRACKET

PRODUCT CATEGORY: SOLAR CONTROL - EXTERIOR SCREEN  
 DRAWING FILE: TUBRISE\_ES\_INSTALL\_HORIZONTAL\_FOLDED  
 SCALE: NOT TO SCALE

**LUXALON**<sup>®</sup>  
 METAL CEILING

**WoodWright**<sup>™</sup>  
 WOOD CEILING

**Techstyle**<sup>®</sup>  
 ACOUSTIC SOLUTIONS

All rights reserved. This drawing is the property of Hunter Douglas and may be used only in conjunction with construction projects utilizing Hunter Douglas products. This detail may not apply to all conditions or construction situations. For non-typical conditions, consult Hunter Douglas.

drawn: CKS  
 date: 04-11  
 section: TUBE  
 page: 03

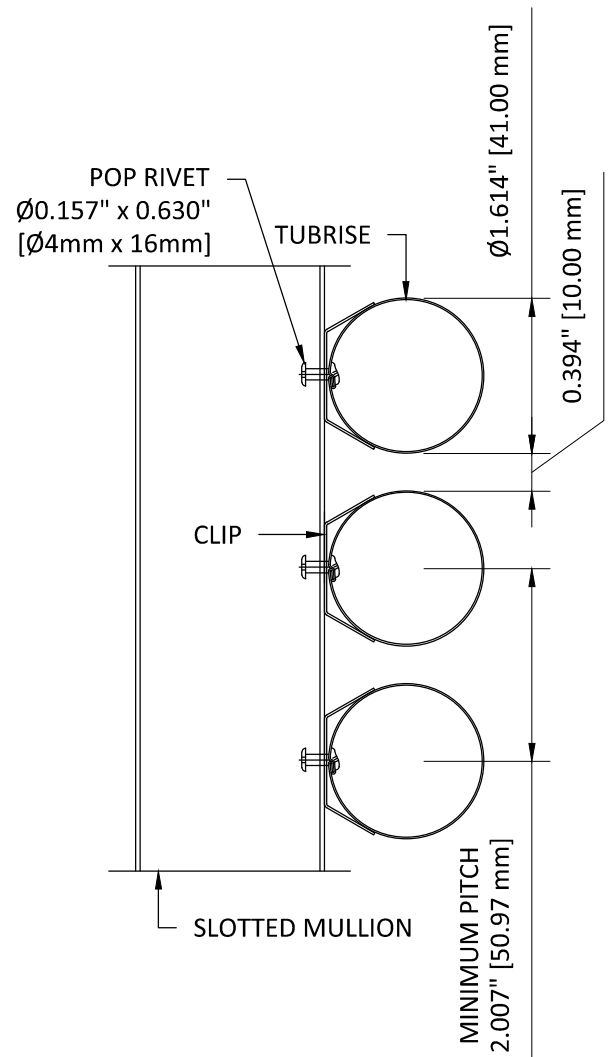
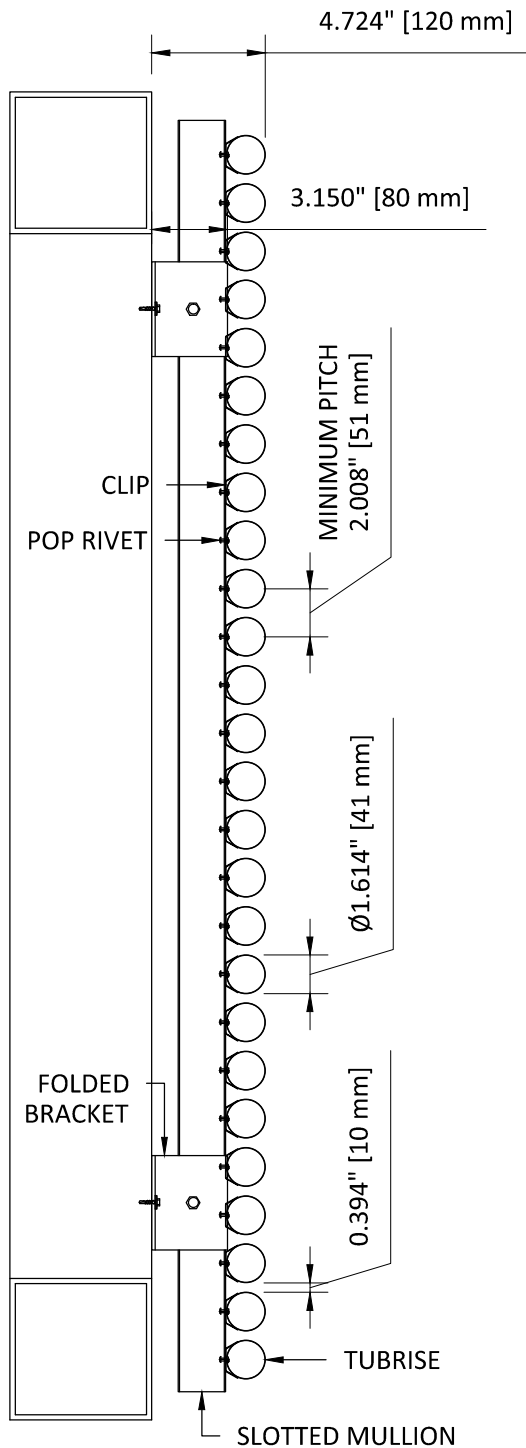

# HunterDouglasContract

## CEILING

1 Hunter Douglas Circle  
 Thornton, CO 80241  
 800-727-8953  
 fax: 720-872-7850

5015 Oakbrook Parkway, Suite 100  
 Norcross, GA 30093  
 800-366-4327 / 770-806-9557  
 fax: 770-806-0217

[www.hunterdouglascontract.com](http://www.hunterdouglascontract.com)

## TUBRISE - HORIZONTAL INSTALLATION SECTION WITH FOLDED BRACKET

PRODUCT CATEGORY: SOLAR CONTROL - EXTERIOR SCREEN  
 DRAWING FILE: TUBRISE\_ES\_INSTALL\_ HORIZONTAL\_SECTION\_FOLDED

**LUXALON**  
 METAL CEILING

**WoodWright**  
 WOOD CEILING

**Techstyle**  
 ACOUSTIC SOLUTIONS

All rights reserved. This drawing is the property of Hunter Douglas and may be used only in conjunction with construction projects utilizing Hunter Douglas products. This detail may not apply to all conditions or construction situations. For non-typical conditions, consult Hunter Douglas.

drawn: CKS  
 date: 04-11  
 section: TUBE  
 page: 04

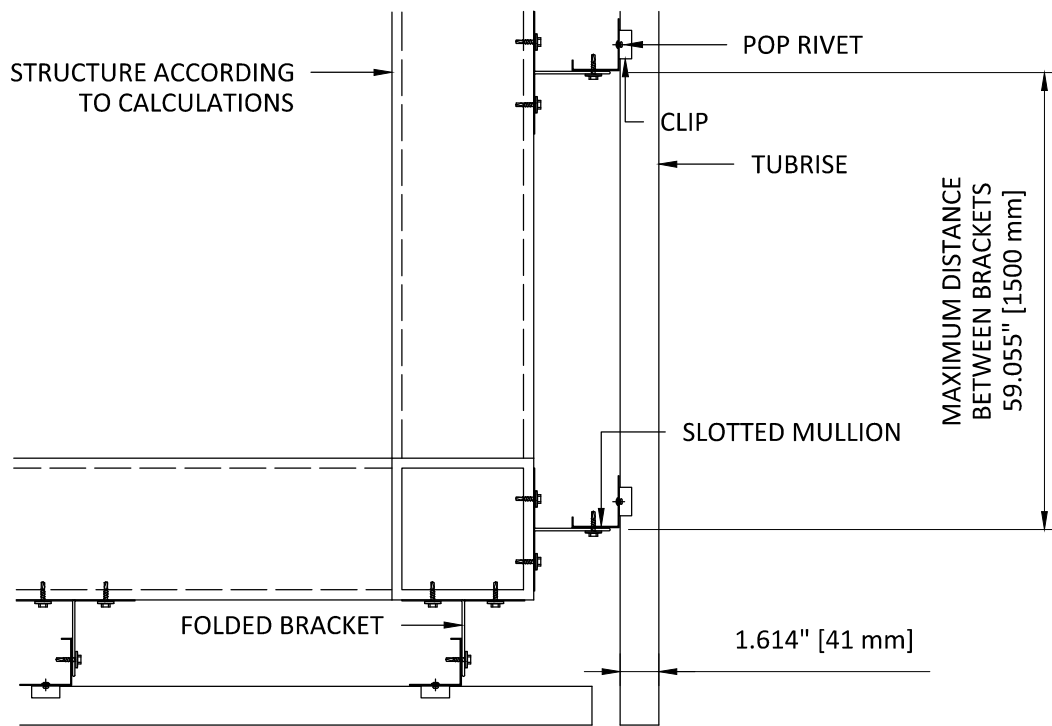
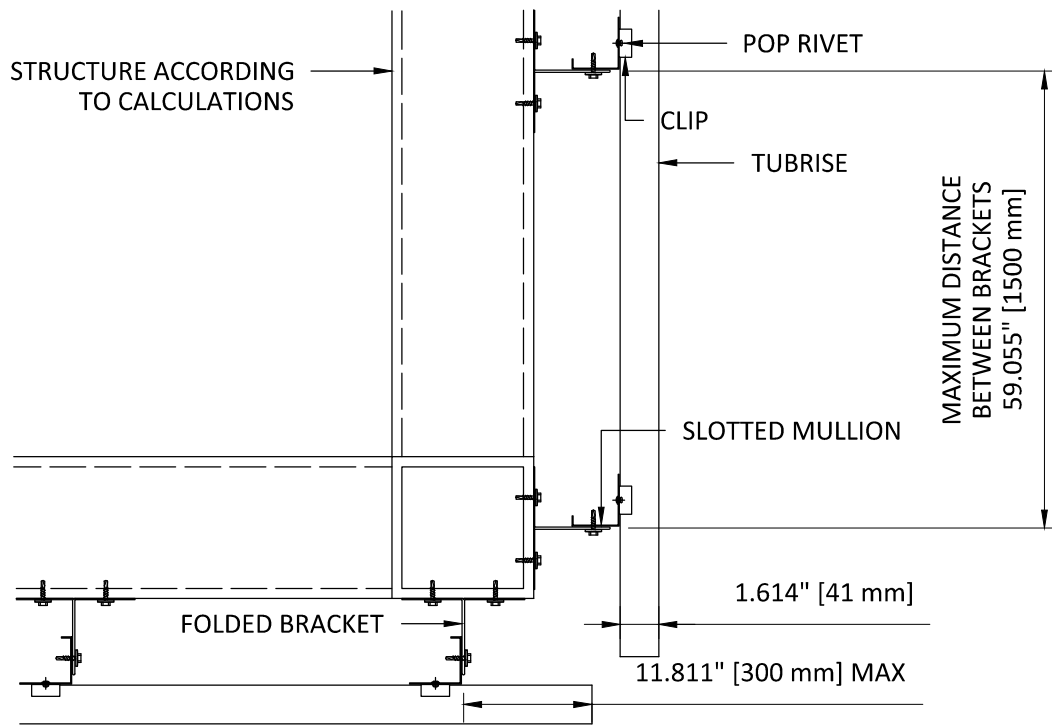

# HunterDouglasContract

## CEILING

1 Hunter Douglas Circle  
 Thornton, CO 80241  
 800-727-8953  
 fax: 720-872-7850

5015 Oakbrook Parkway, Suite 100  
 Norcross, GA 30093  
 800-366-4327 / 770-806-9557  
 fax: 770-806-0217

[www.hunterdouglascontract.com](http://www.hunterdouglascontract.com)

## TUBRISE - HORIZONTAL INSTALLATION CORNER DETAILS WITH FOLDED BRACKET

PRODUCT CATEGORY: SOLAR CONTROL - EXTERIOR SCREEN  
 DRAWING FILE: TUBRISE\_ES\_HORIZONTAL\_CORNER\_FOLDED  
 SCALE: 1 1/2" = 1'-0"

**LUXALON**<sup>®</sup>  
 METAL CEILING

**WoodWright**<sup>™</sup>  
 WOOD CEILING

**Techstyle**<sup>®</sup>  
 ACOUSTIC SOLUTIONS

All rights reserved. This drawing is the property of Hunter Douglas and may be used only in conjunction with construction projects utilizing Hunter Douglas products. This detail may not apply to all conditions or construction situations. For non-typical conditions, consult Hunter Douglas.

drawn: CKS  
 date: 04-11  
 section: TUBE  
 page: 05

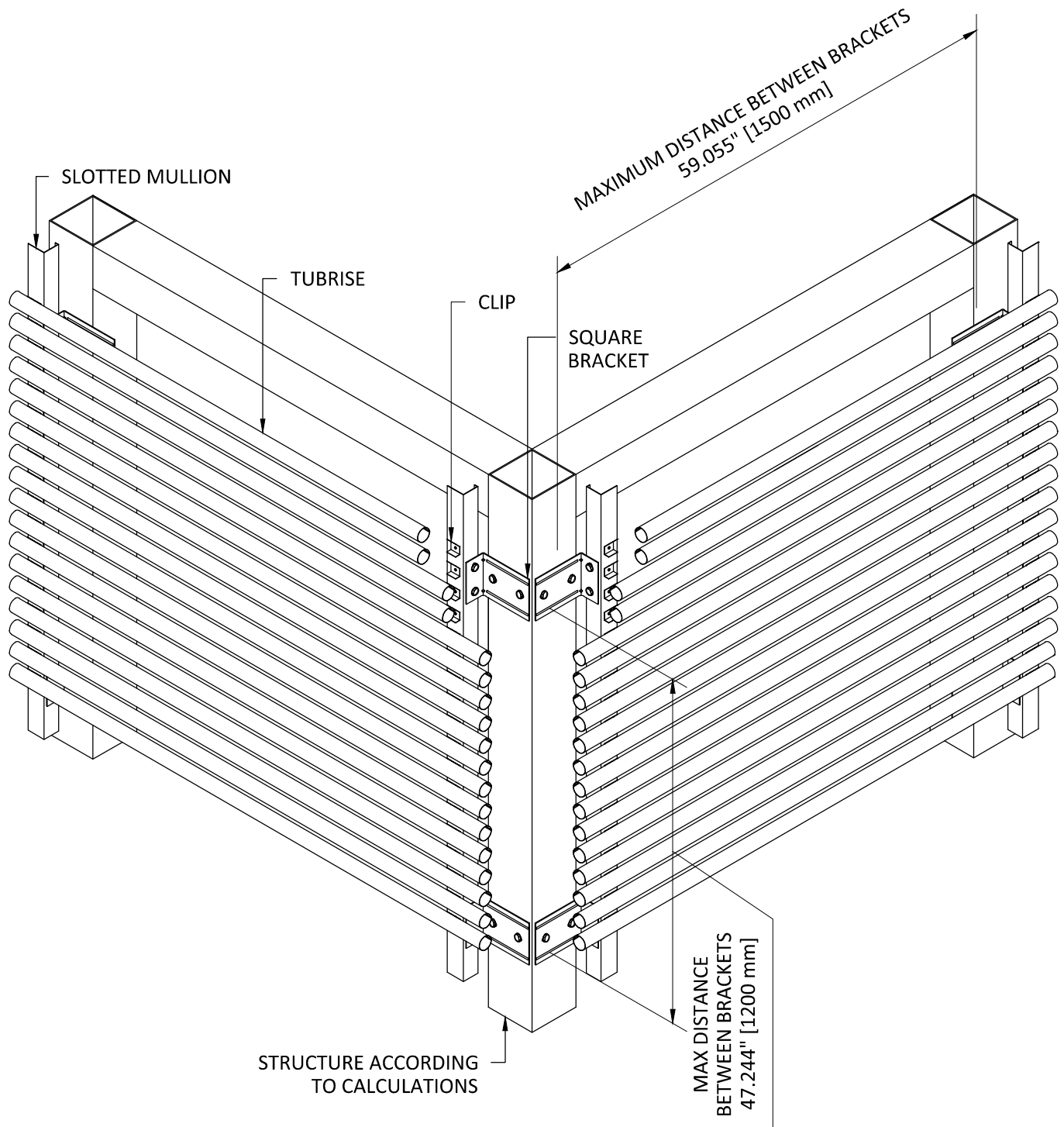

# HunterDouglasContract

## CEILING

1 Hunter Douglas Circle  
Thornton, CO 80241  
800-727-8953  
fax: 720-872-7850

5015 Oakbrook Parkway, Suite 100  
Norcross, GA 30093  
800-366-4327 / 770-806-9557  
fax: 770-806-0217

[www.hunterdouglascontract.com](http://www.hunterdouglascontract.com)

## TUBRISE - HORIZONTAL INSTALLATION WITH SQUARE BRACKETS

PRODUCT CATEGORY: SOLAR CONTROL - EXTERIOR SCREEN  
DRAWING FILE: TUBRISE\_ES\_INSTALL\_HORIZONTAL\_SQUARE  
SCALE: NOT TO SCALE

**LUXALON**<sup>®</sup>  
METAL CEILING

**WoodWright**<sup>™</sup>  
WOOD CEILING

**Techstyle**<sup>®</sup>  
ACOUSTIC SOLUTIONS

All rights reserved. This drawing is the property of Hunter Douglas and may be used only in conjunction with construction projects utilizing Hunter Douglas products. This detail may not apply to all conditions or construction situations. For non-typical conditions, consult Hunter Douglas.

drawn: CKS  
date: 04-11  
section: TUBE  
page: 06



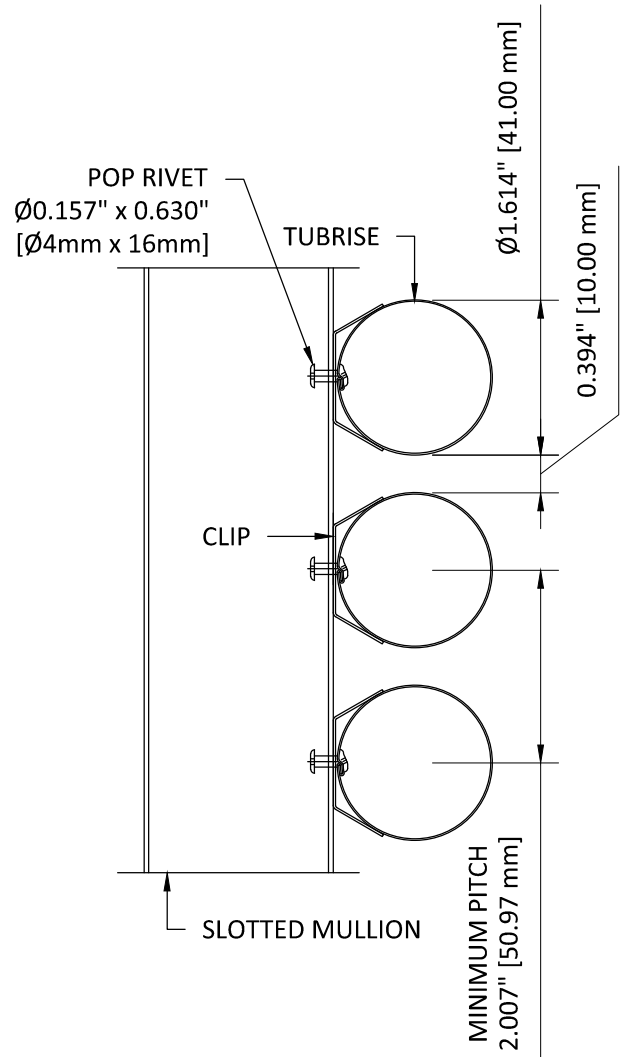
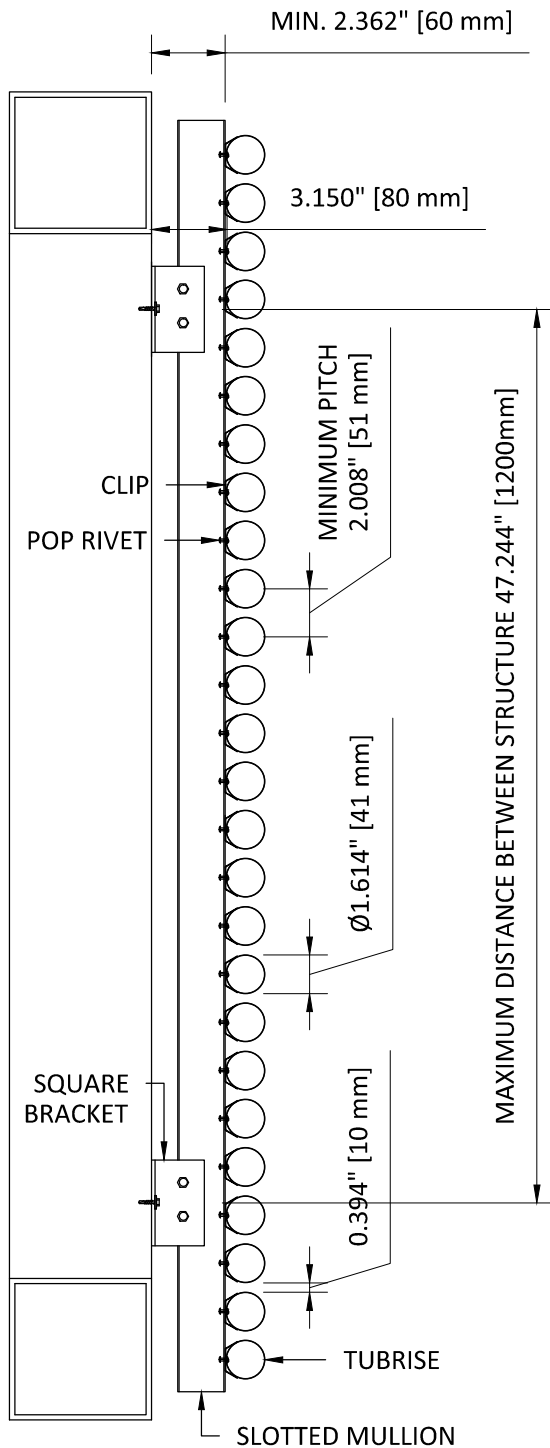

# HunterDouglasContract

## CEILING

1 Hunter Douglas Circle  
 Thornton, CO 80241  
 800-727-8953  
 fax: 720-872-7850

5015 Oakbrook Parkway, Suite 100  
 Norcross, GA 30093  
 800-366-4327 / 770-806-9557  
 fax: 770-806-0217

[www.hunterdouglascontract.com](http://www.hunterdouglascontract.com)

## TUBRISE - HORIZONTAL INSTALLATION SECTION WITH SQUARE BRACKET

PRODUCT CATEGORY: SOLAR CONTROL - EXTERIOR SCREEN  
 DRAWING FILE: TUBRISE\_ES\_INSTALL\_ HORIZONTAL\_SECTION\_SQUARE

**LUXALON**  
 METAL CEILING

**WoodWright**  
 WOOD CEILING

**Techstyle**  
 ACOUSTIC SOLUTIONS

All rights reserved. This drawing is the property of Hunter Douglas and may be used only in conjunction with construction projects utilizing Hunter Douglas products. This detail may not apply to all conditions or construction situations. For non-typical conditions, consult Hunter Douglas.

drawn: CKS  
 date: 04-11  
 section: TUBE  
 page: 07

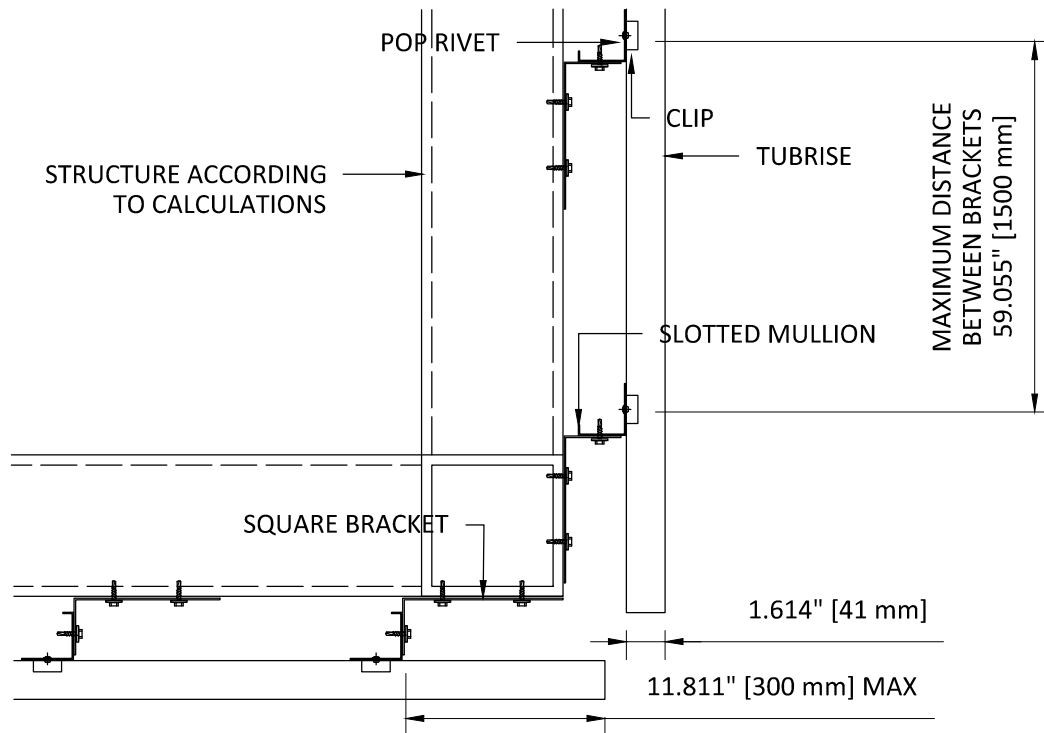

# HunterDouglasContract

## CEILINGS

1 Hunter Douglas Circle  
 Thornton, CO 80241  
 800-727-8953  
 fax: 720-872-7850

5015 Oakbrook Parkway, Suite 100  
 Norcross, GA 30093  
 800-366-4327 / 770-806-9557  
 fax: 770-806-0217

[www.hunterdouglascontract.com](http://www.hunterdouglascontract.com)

## TUBRISE - HORIZONTAL INSTALLATION CORNER DETAIL WITH SQUARE BRACKET

PRODUCT CATEGORY: SOLAR CONTROL - EXTERIOR SCREEN  
 DRAWING FILE: TUBRISE\_ES\_HORIZONTAL\_CORNER\_SQUARE  
 SCALE: 1 1/2" = 1'-0"

**LUXALON**<sup>®</sup>  
 METAL CEILINGS

**WoodWright**<sup>™</sup>  
 WOOD CEILINGS

**Techstyle**<sup>®</sup>  
 ACOUSTIC SOLUTIONS

All rights reserved. This drawing is the property of Hunter Douglas and may be used only in conjunction with construction projects utilizing Hunter Douglas products. This detail may not apply to all conditions or construction situations. For non-typical conditions, consult Hunter Douglas.

drawn: CKS  
 date: 04-11  
 section: TUBE  
 page: 08

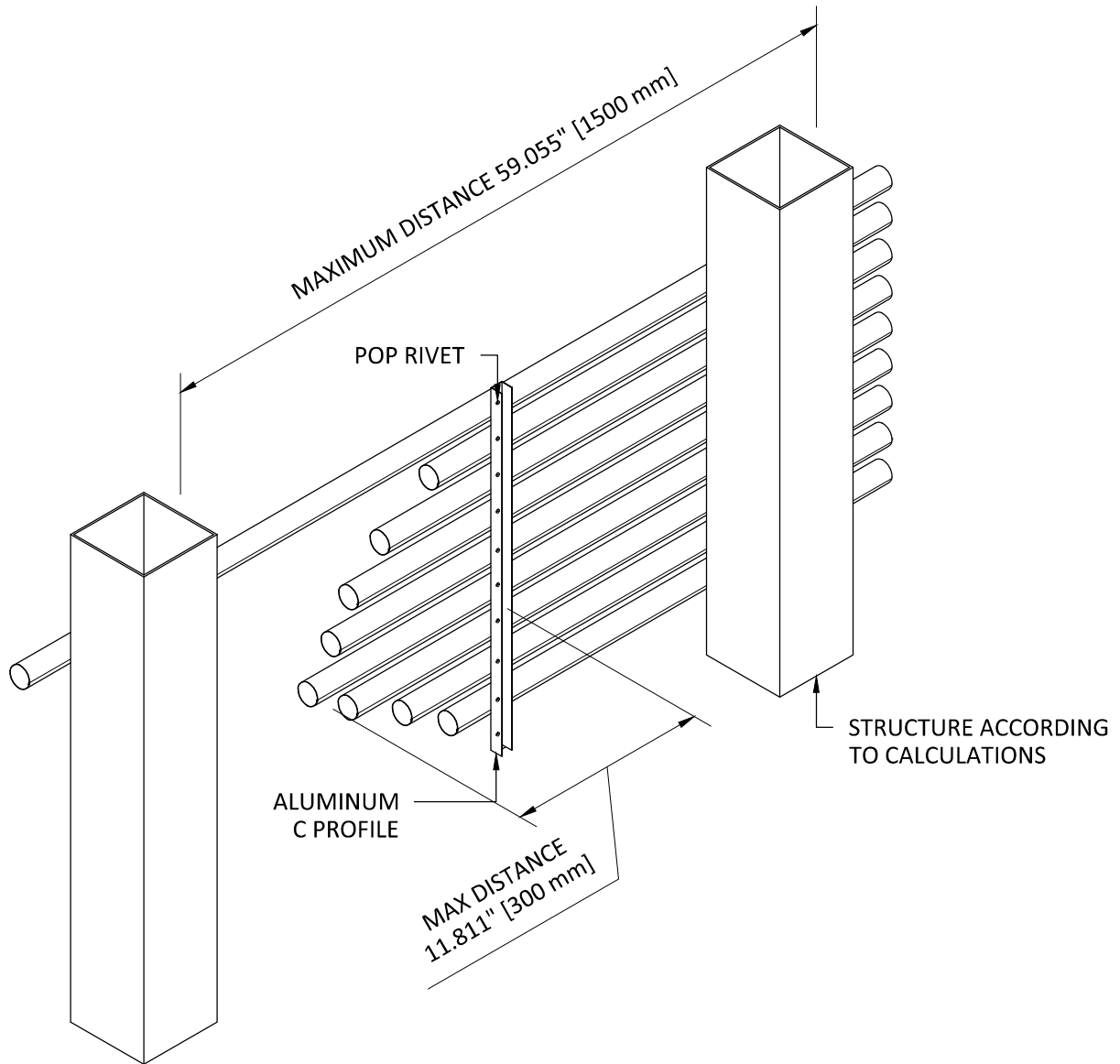

# HunterDouglasContract

## CEILINGS

1 Hunter Douglas Circle  
 Thornton, CO 80241  
 800-727-8953  
 fax: 720-872-7850

5015 Oakbrook Parkway, Suite 100  
 Norcross, GA 30093  
 800-366-4327 / 770-806-9557  
 fax: 770-806-0217

[www.hunterdouglascontract.com](http://www.hunterdouglascontract.com)

## TUBRISE - HORIZONTAL INSTALLATION WITH C-PROFILE

PRODUCT CATEGORY: SOLAR CONTROL - EXTERIOR SCREEN  
 DRAWING FILE: TUBRISE\_ES\_INSTALL\_HORIZONTAL\_C-PROFILE  
 SCALE: NOT TO SCALE

**LUXALON**<sup>®</sup>  
 METAL CEILINGS

**WoodWright**<sup>™</sup>  
 WOOD CEILINGS

**Techstyle**<sup>®</sup>  
 ACOUSTIC SOLUTIONS

All rights reserved. This drawing is the property of Hunter Douglas and may be used only in conjunction with construction projects utilizing Hunter Douglas products. This detail may not apply to all conditions or construction situations. For non-typical conditions, consult Hunter Douglas.

drawn: CKS  
 date: 04-11  
 section: TUBE  
 page: 09

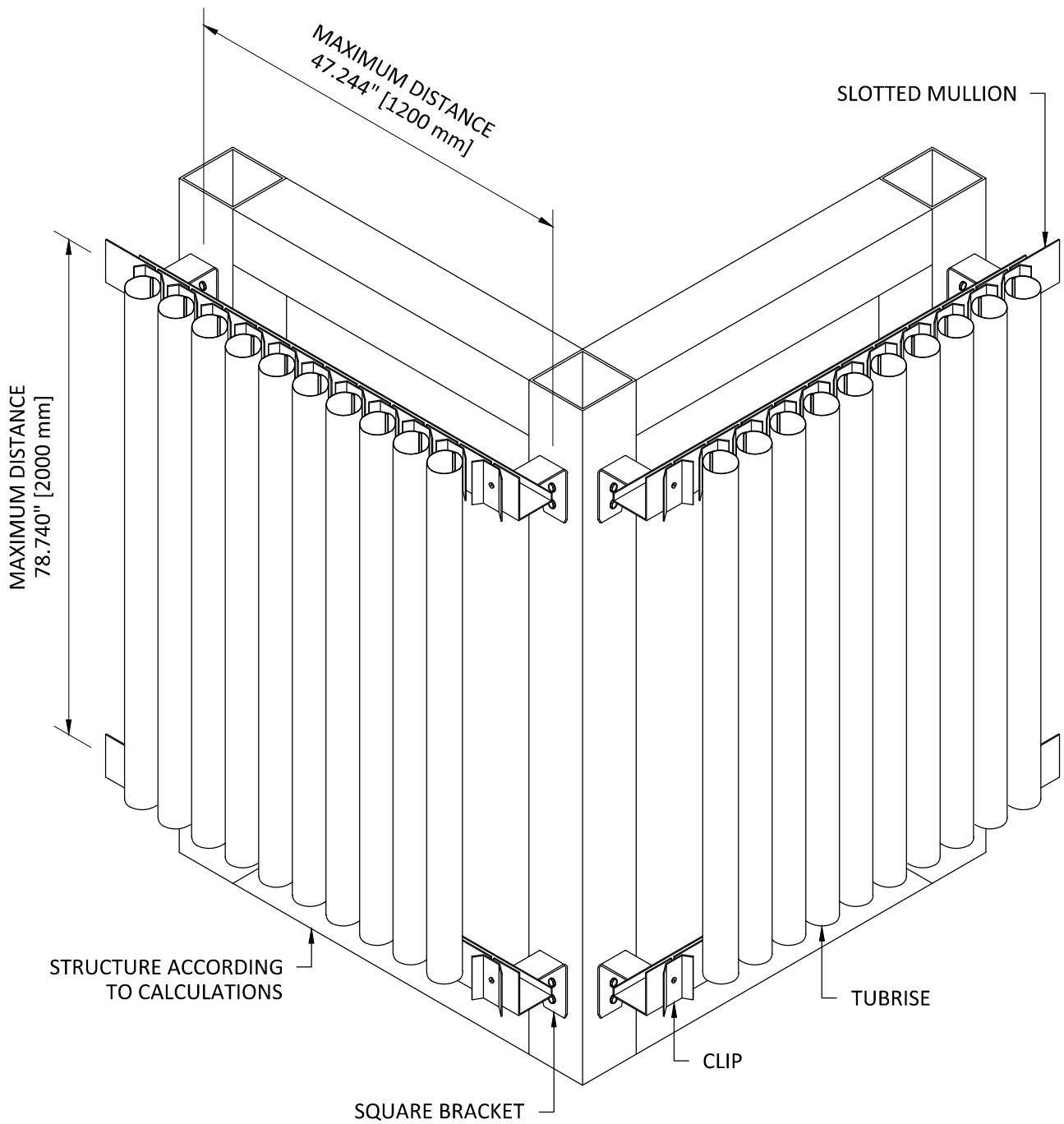

# HunterDouglasContract

## CEILING

1 Hunter Douglas Circle  
 Thornton, CO 80241  
 800-727-8953  
 fax: 720-872-7850

5015 Oakbrook Parkway, Suite 100  
 Norcross, GA 30093  
 800-366-4327 / 770-806-9557  
 fax: 770-806-0217

[www.hunterdouglascontract.com](http://www.hunterdouglascontract.com)

## TUBRISE - VERTICAL INSTALLATION WITH SQUARE BRACKETS

PRODUCT CATEGORY: SOLAR CONTROL - EXTERIOR SCREEN  
 DRAWING FILE: TUBRISE\_ES\_INSTALL\_VERTICAL\_SQUARE  
 SCALE: NOT TO SCALE

**LUXALON**<sup>®</sup>  
 METAL CEILING

**WoodWright**<sup>™</sup>  
 WOOD CEILING

**Techstyle**<sup>®</sup>  
 ACOUSTIC SOLUTIONS

All rights reserved. This drawing is the property of Hunter Douglas and may be used only in conjunction with construction projects utilizing Hunter Douglas products. This detail may not apply to all conditions or construction situations. For non-typical conditions, consult Hunter Douglas.

drawn: CKS  
 date: 04-11  
 section: TUBE  
 page: 10

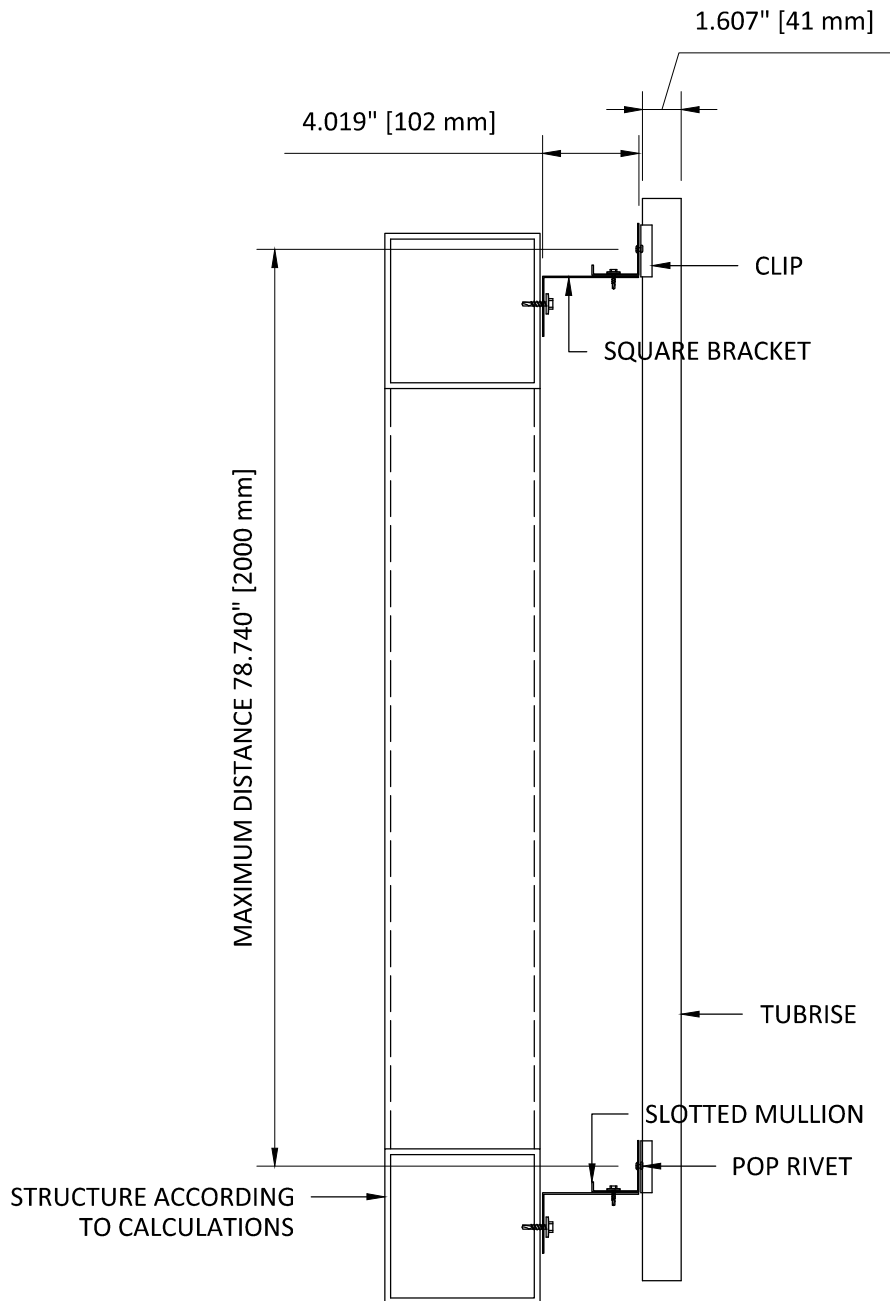

# HunterDouglasContract

## CEILINGS

1 Hunter Douglas Circle  
 Thornton, CO 80241  
 800-727-8953  
 fax: 720-872-7850

5015 Oakbrook Parkway, Suite 100  
 Norcross, GA 30093  
 800-366-4327 / 770-806-9557  
 fax: 770-806-0217

[www.hunterdouglascontract.com](http://www.hunterdouglascontract.com)

## TUBRISE - VERTICAL INSTALLATION SECTION WITH SQUARE BRACKET

PRODUCT CATEGORY: SOLAR CONTROL - EXTERIOR SCREEN  
 DRAWING FILE: TUBRISE\_ES\_INSTALL\_  
 SCALE: 1 1/2" = 1'-0" VERTICAL\_SECTION\_SQUARE

**LUXALON**<sup>®</sup>  
 METAL CEILINGS

**WoodWright**<sup>™</sup>  
 WOOD CEILINGS

**Techstyle**<sup>®</sup>  
 ACOUSTIC SOLUTIONS

All rights reserved. This drawing is the property of Hunter Douglas and may be used only in conjunction with construction projects utilizing Hunter Douglas products. This detail may not apply to all conditions or construction situations. For non-typical conditions, consult Hunter Douglas.

drawn: CKS  
 date: 04-11  
 section: TUBE  
 page: 11

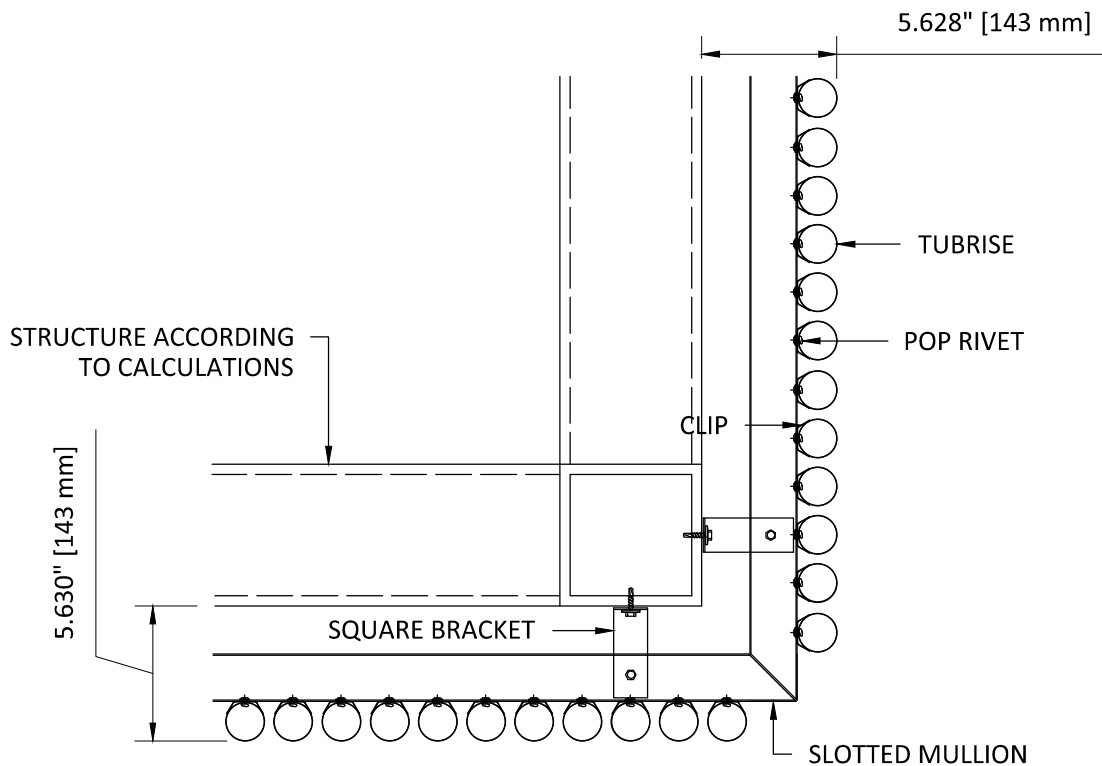
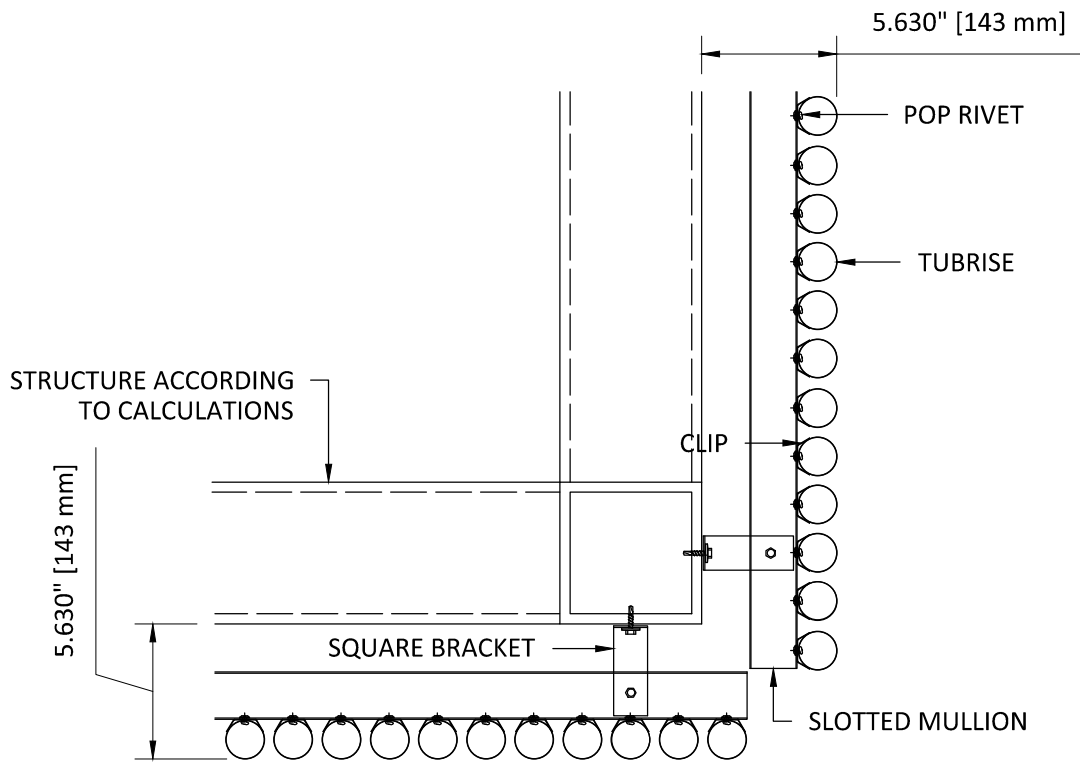

# HunterDouglasContract

## CEILING

1 Hunter Douglas Circle  
Thornton, CO 80241  
800-727-8953  
fax: 720-872-7850

5015 Oakbrook Parkway, Suite 100  
Norcross, GA 30093  
800-366-4327 / 770-806-9557  
fax: 770-806-0217

[www.hunterdouglascontract.com](http://www.hunterdouglascontract.com)

## TUBRISE - VERTICAL INSTALLATION CORNER DETAILS WITH SQUARE BRACKET

PRODUCT CATEGORY: SOLAR CONTROL - EXTERIOR SCREEN  
DRAWING FILE: TUBRISE\_ES\_VERTICAL\_CORNER\_SQUARE  
SCALE: 1 1/2" = 1'-0"

**LUXALON**<sup>®</sup>  
METAL CEILING

**WoodWright**<sup>™</sup>  
WOOD CEILING

**Techstyle**<sup>®</sup>  
ACOUSTIC SOLUTIONS

All rights reserved. This drawing is the property of Hunter Douglas and may be used only in conjunction with construction projects utilizing Hunter Douglas products. This detail may not apply to all conditions or construction situations. For non-typical conditions, consult Hunter Douglas.

drawn: CKS  
date: 04-11  
section: TUBE  
page: 12

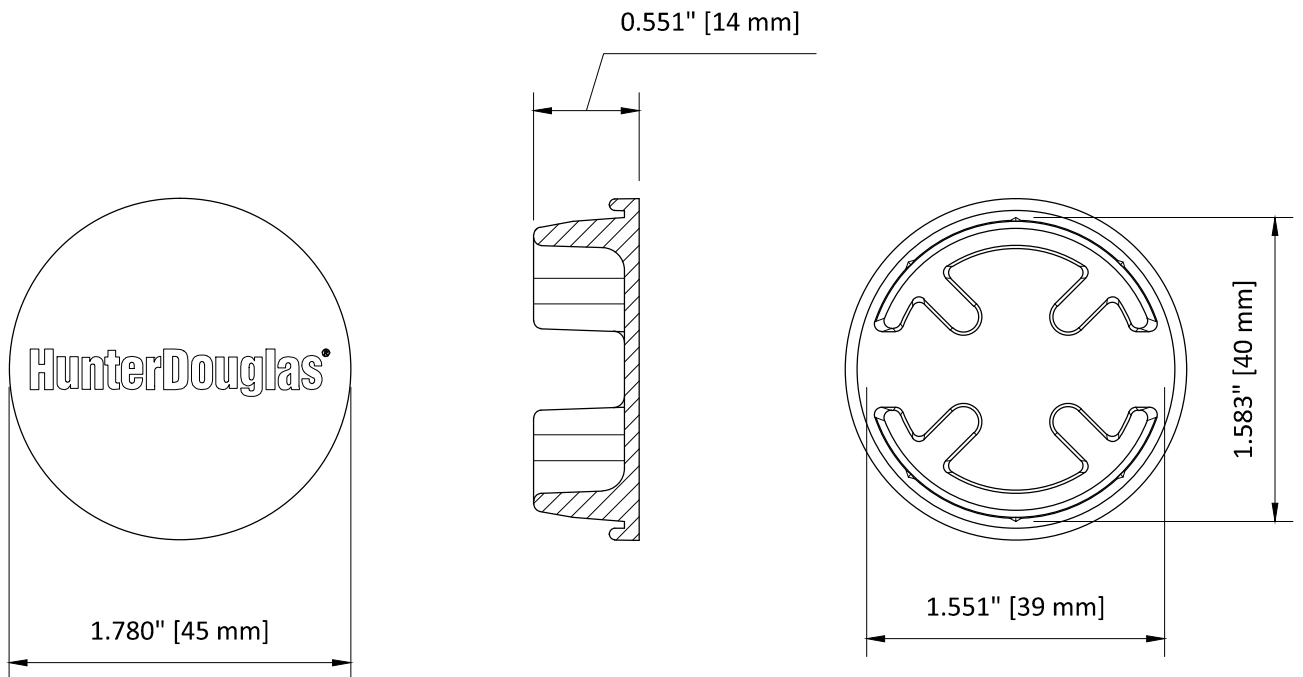
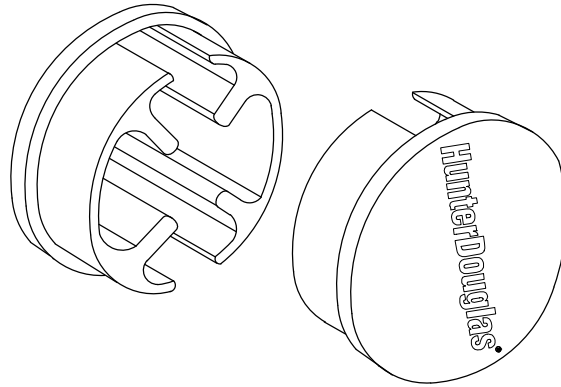

# HunterDouglasContract

## CEILING

1 Hunter Douglas Circle  
 Thornton, CO 80241  
 800-727-8953  
 fax: 720-872-7850

5015 Oakbrook Parkway, Suite 100  
 Norcross, GA 30093  
 800-366-4327 / 770-806-9557  
 fax: 770-806-0217

[www.hunterdouglascontract.com](http://www.hunterdouglascontract.com)

## TUBRISE - END CAP COMPONENTS

PRODUCT CATEGORY: SOLAR CONTROL - EXTERIOR SCREEN  
 DRAWING FILE: TUBRISE\_ES\_COMPONENT\_END CAP  
 SCALE: 1:1

**LUXALON**<sup>®</sup>  
 METAL CEILING

**WoodWright**<sup>™</sup>  
 WOOD CEILING

**Techstyle**<sup>®</sup>  
 ACOUSTIC SOLUTIONS

All rights reserved. This drawing is the property of Hunter Douglas and may be used only in conjunction with construction projects utilizing Hunter Douglas products. This detail may not apply to all conditions or construction situations. For non-typical conditions, consult Hunter Douglas.

drawn: CKS  
 date: 04-11  
 section: TUBE  
 page: 13

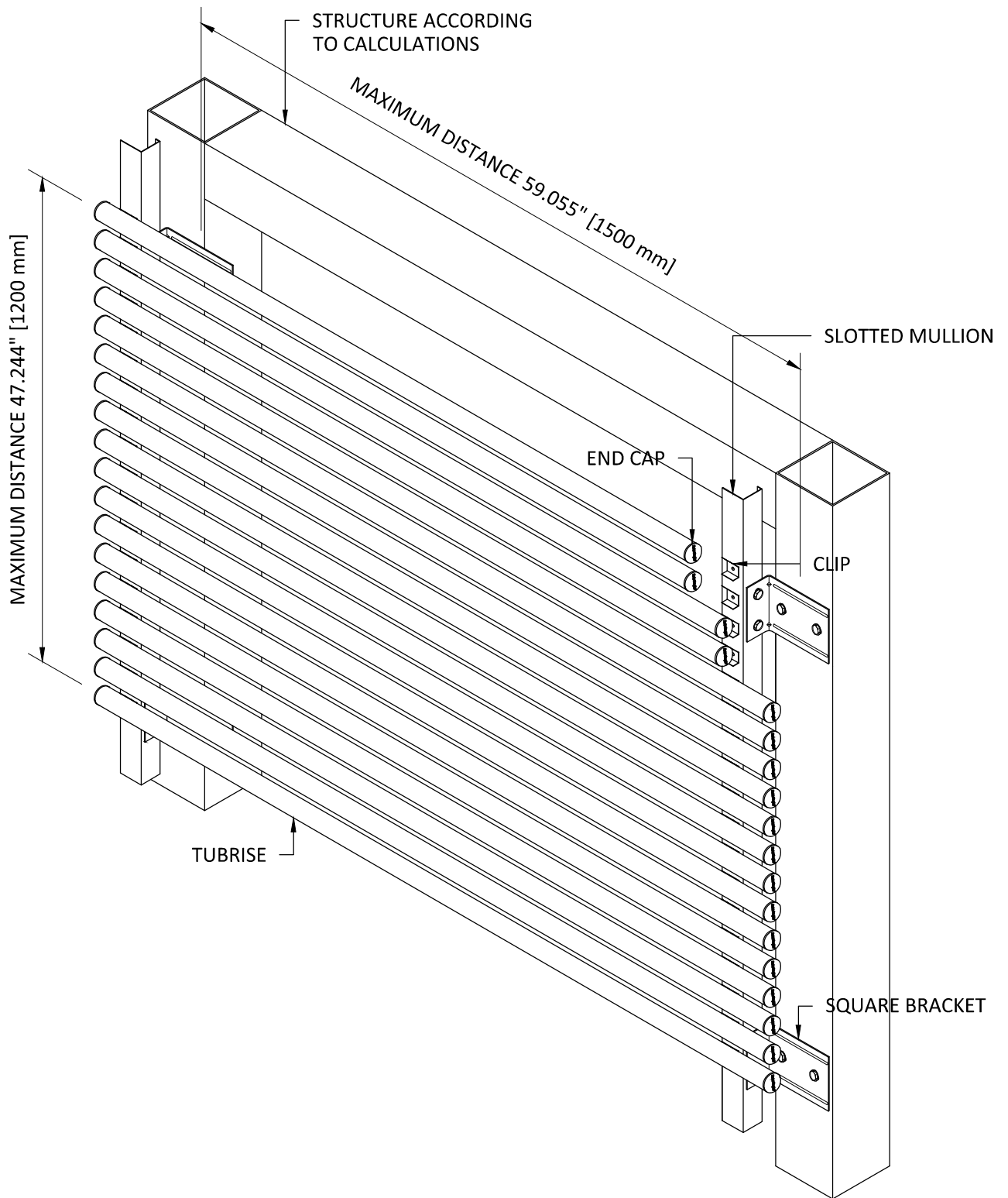

# HunterDouglasContract

## CEILING

1 Hunter Douglas Circle  
 Thornton, CO 80241  
 800-727-8953  
 fax: 720-872-7850

5015 Oakbrook Parkway, Suite 100  
 Norcross, GA 30093  
 800-366-4327 / 770-806-9557  
 fax: 770-806-0217

[www.hunterdouglascontract.com](http://www.hunterdouglascontract.com)

## TUBRISE - HORIZONTAL INSTALLATION WITH END CAPS AND SQUARE BRACKET

PRODUCT CATEGORY: SOLAR CONTROL - EXTERIOR SCREEN  
 DRAWING FILE: TUBRISE\_ES\_INSTALL\_HORIZONTAL\_END CAP  
 SCALE: 1 1/2" = 1'-0"

**LUXALON**<sup>®</sup>  
 METAL CEILING

**WoodWright**<sup>™</sup>  
 WOOD CEILING

**Techstyle**<sup>®</sup>  
 ACOUSTIC SOLUTIONS

All rights reserved. This drawing is the property of Hunter Douglas and may be used only in conjunction with construction projects utilizing Hunter Douglas products. This detail may not apply to all conditions or construction situations. For non-typical conditions, consult Hunter Douglas.

drawn: CKS  
 date: 04-11  
 section: TUBE  
 page: 14



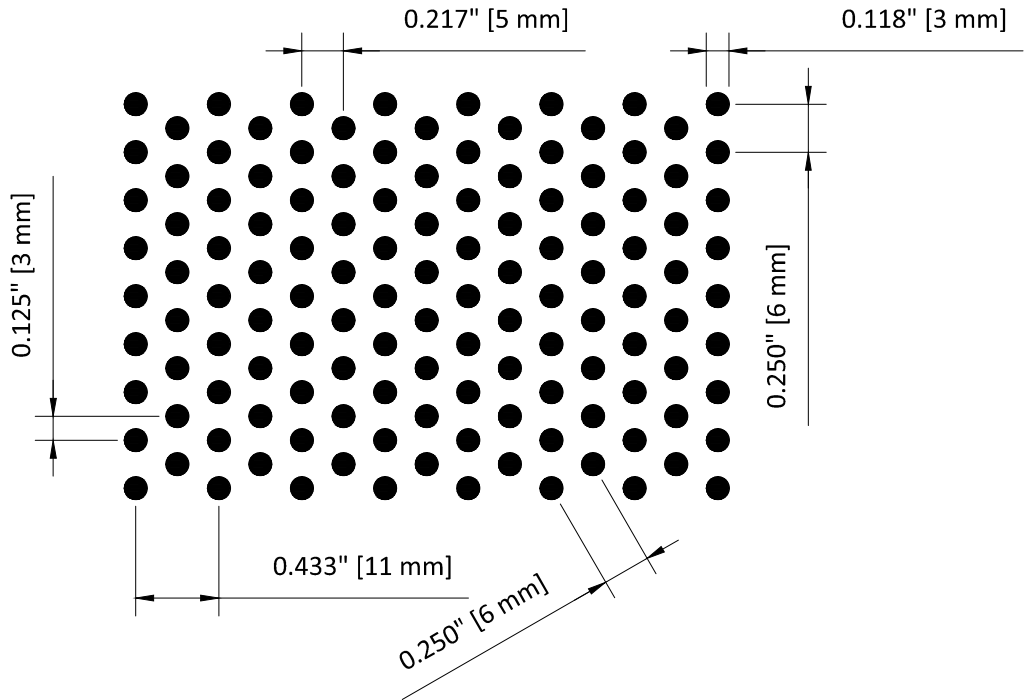

**PERFORATION 103:**

- 0.118" [3 mm] DIAMETER
- STAGGERED 60°
- 20% OPEN AREA
- DIRECTION →

# HunterDouglasContract

**CEILINGS**

1 Hunter Douglas Circle  
 Thornton, CO 80241  
 800-727-8953  
 fax: 720-872-7850

5015 Oakbrook Parkway, Suite 100  
 Norcross, GA 30093  
 800-366-4327 / 770-806-9557  
 fax: 770-806-0217

[www.hunterdouglascontract.com](http://www.hunterdouglascontract.com)

## TUBRISE - PERFORATION 103

PRODUCT CATEGORY: SOLAR CONTROL - EXTERIOR SCREEN  
 DRAWING FILE: TUBRISE\_ES\_PERFORATION\_103  
 SCALE: 1:1

**LUXALON**<sup>®</sup>  
 METAL CEILINGS

**WoodWright**<sup>™</sup>  
 WOOD CEILINGS

**Techstyle**<sup>®</sup>  
 ACOUSTIC SOLUTIONS

*All rights reserved. This drawing is the property of Hunter Douglas and may be used only in conjunction with construction projects utilizing Hunter Douglas products. This detail may not apply to all conditions or construction situations. For non-typical conditions, consult Hunter Douglas.*

drawn: CKS  
 date: 04-11  
 section: TUBE  
 page: 15

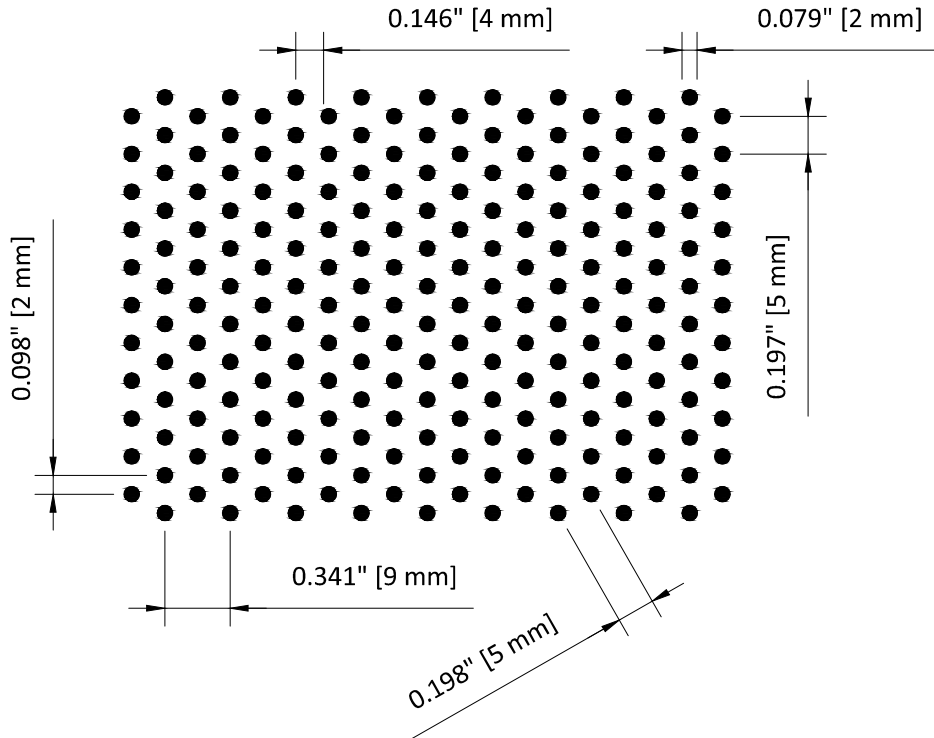

**PERFORATION 118:**

- 0.079" [2 mm] DIAMETER
- STAGGERED 60°
- 20% OPEN AREA
- DIRECTION →

# HunterDouglasContract

**CEILINGS**

1 Hunter Douglas Circle  
 Thornton, CO 80241  
 800-727-8953  
 fax: 720-872-7850

5015 Oakbrook Parkway, Suite 100  
 Norcross, GA 30093  
 800-366-4327 / 770-806-9557  
 fax: 770-806-0217

[www.hunterdouglascontract.com](http://www.hunterdouglascontract.com)

## TUBRISE - PERFORATION 118

PRODUCT CATEGORY: SOLAR CONTROL - EXTERIOR SCREEN  
 DRAWING FILE: TUBRISE\_ES\_PERFORATION\_118  
 SCALE: 1:1

**LUXALON**<sup>®</sup>  
 METAL CEILINGS

**WoodWright**<sup>™</sup>  
 WOOD CEILINGS

**Techstyle**<sup>®</sup>  
 ACOUSTIC SOLUTIONS

*All rights reserved. This drawing is the property of Hunter Douglas and may be used only in conjunction with construction projects utilizing Hunter Douglas products. This detail may not apply to all conditions or construction situations. For non-typical conditions, consult Hunter Douglas.*

drawn: CKS  
 date: 04-11  
 section: TUBE  
 page: 15

5015 Oakbrook Parkway, Suite 100  
Norcross, GA 30093  
800-366-4327 / 770-806-9557  
fax: 770-806-0217

[www.hunterdouglascontract.com](http://www.hunterdouglascontract.com)

**HunterDouglasContract**

CEILINGS